



[www.matterofstuff.com](http://www.matterofstuff.com)



# Content

## Furniture

1. Luminarie Collection by Sabina Belifore Lucovic 6
2. Club Chair by Glen Baghurst 12
3. Marque' by Alessandro Zambelli 14
4. Echo by Uufie 22
5. Feather by Tomas Libertiny 30
6. Lithosphere by Studio deFORM 32
7. Coulee by Nina Cho 36
8. The Veiled by Olga Bielawska 38
9. Remetaled by Tim Vanlier 42
10. Mirrored by Tim Vanlier 44

## Lighting

11. Marble Cone by Ariel Zuckerman 46
12. Asymmetric by Ariel Zuckerman 48

## Accessories

13. NODA by Karsan Haval, Phoebe Morris, Lara Chapman 50
14. Deskcape by Arturo Soto, Nathalie Pitchler 52
15. Svelata by Moreno Ratti 54
17. Curvy by Ariel Zuckerman 56
18. Full Bowl by Sebastian Bergne 58
19. Flower Vessel & Wine Cooler by Guglielmo Maggini 60
20. The Wave by Kai-Hua Tsai 64
21. BRUNELLO DI MONTALCINO 2011 65



---

## MATTER OF STUFF

Matter of Stuff is a London based creative studio and collective of manufacturers established in 2014.

Co-founders Simona Auteri and Sofia Steffenoni coordinate community of designers, manufacturers, film makers and storytellers with the aim of promoting a culture where craftsmanship is at the heart of any creation.

Our work spans between design, craftsmanship, architecture, communication and art.. but we don't fit in any of them. Our core team include architects, cutting edge joinery, ceramicists, metalwork and stone facilities, glassblowers and a filmmaker.

Supported by our collaborative community of creatives and makers, we can realize and curate unique and edition work that are contaminated by craftsmanship, design and architecture, be it a one off piece, an installation, or an interior space. The range of products brought together by MOS combine cutting-edge techniques with traditional craftsmanship, serving to reinvigorate the collective imagination.

Throughout a yearly residency program, MOS promotes exchange between the manufacturing and the design world. With specific on-site workshops, MOS works with Universities to facilitate the relationship between design students and the manufacturing world.







# Luminarie Collection

Design: Sabina Belfiore Lucovich

Luminarie is an expressive study of lighting as a poetic object, inspired by the designer's memories of lights at religious festivals in southern Italy. Tactile, playful, illusory and mobile, Luminarie are very light-weight, ethereal structures; handcrafted in Italy from copper and with micro LEDs.

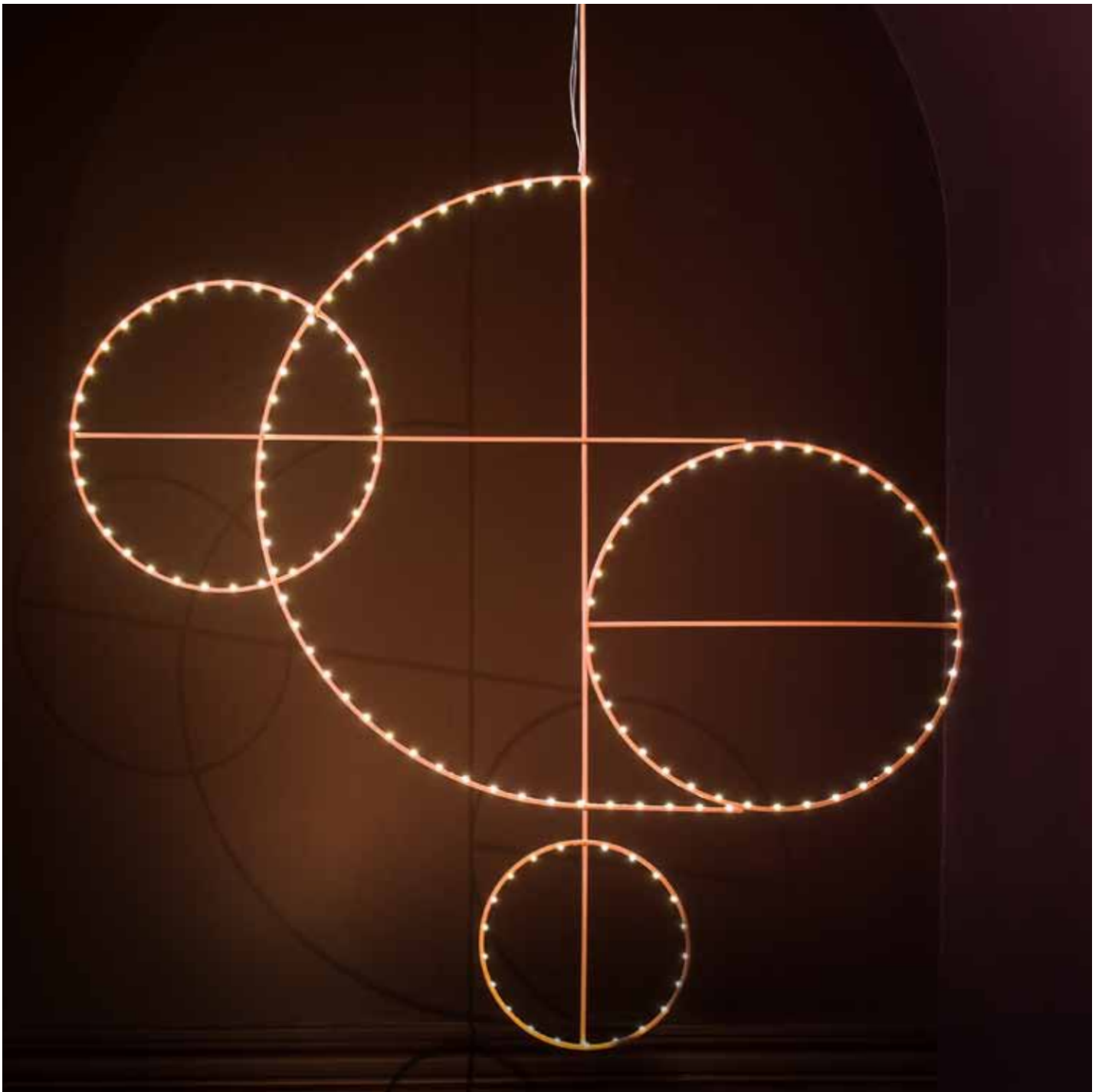

# Belladonna

---

## Luminarie - Belladonna

Hand Made in Italy

Dimensions:

Light: 1020 x 1040 mm

Materials: Steel, copper finish, micro LEDs





# Candelora

---

## Luminarie - Candelora

Hand Made in Italy

Dimensions:

Light: 1450 x 800 mm

Materials: Steel, copper finish, micro LEDs





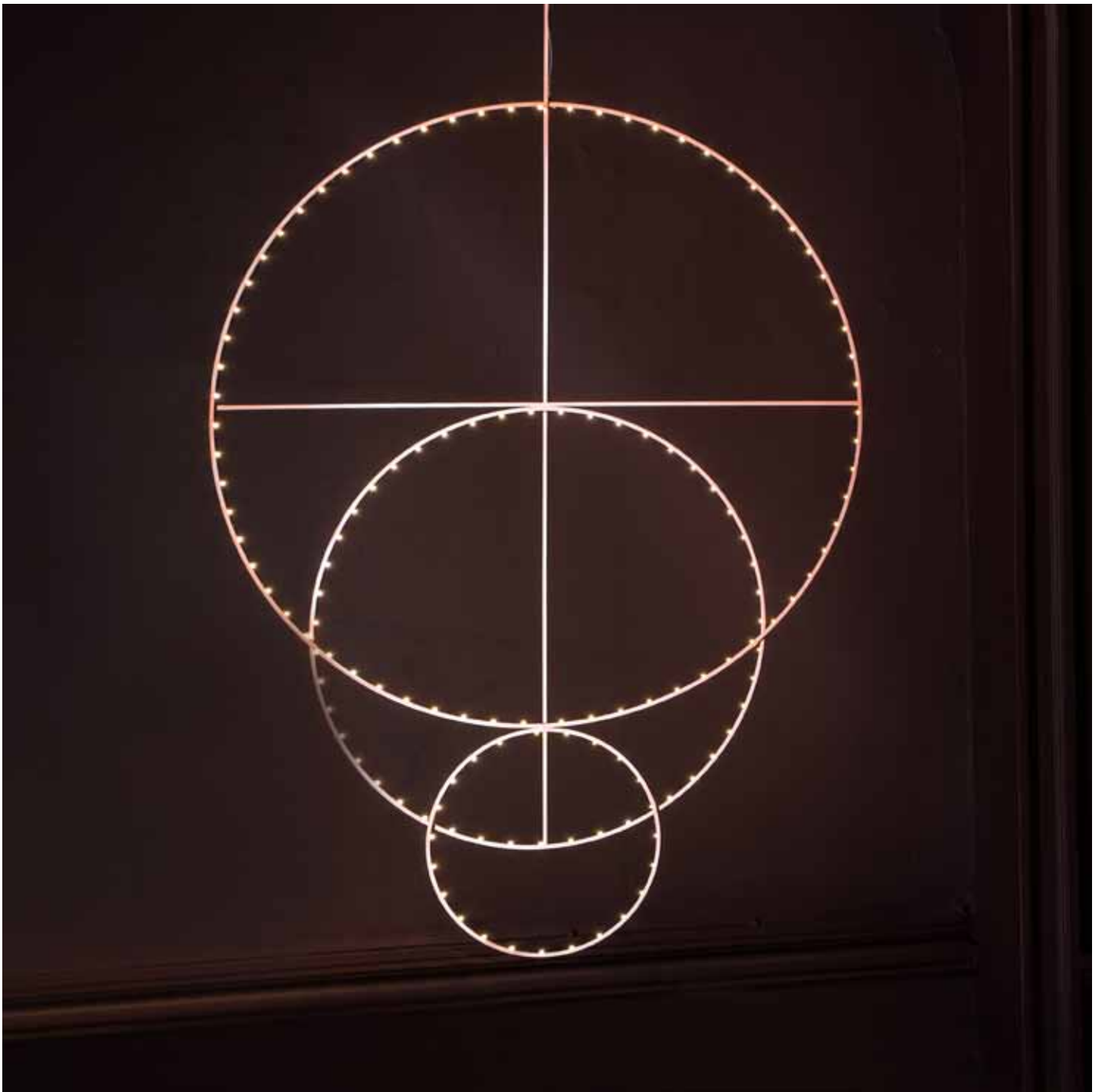

# Novina

---

## Luminarie - Novina

Hand Made in Italy

Dimensions:

Light: 1920 x 700 mm

Materials: Steel, copper finish, micro LEDs





# Luminarie Santamaria I

---

## Luminarie Santamaria I

Hand Made in Italy

Dimensions:

Light: 2380 x 1640 mm

Materials: Steel, copper finish, micro LEDs



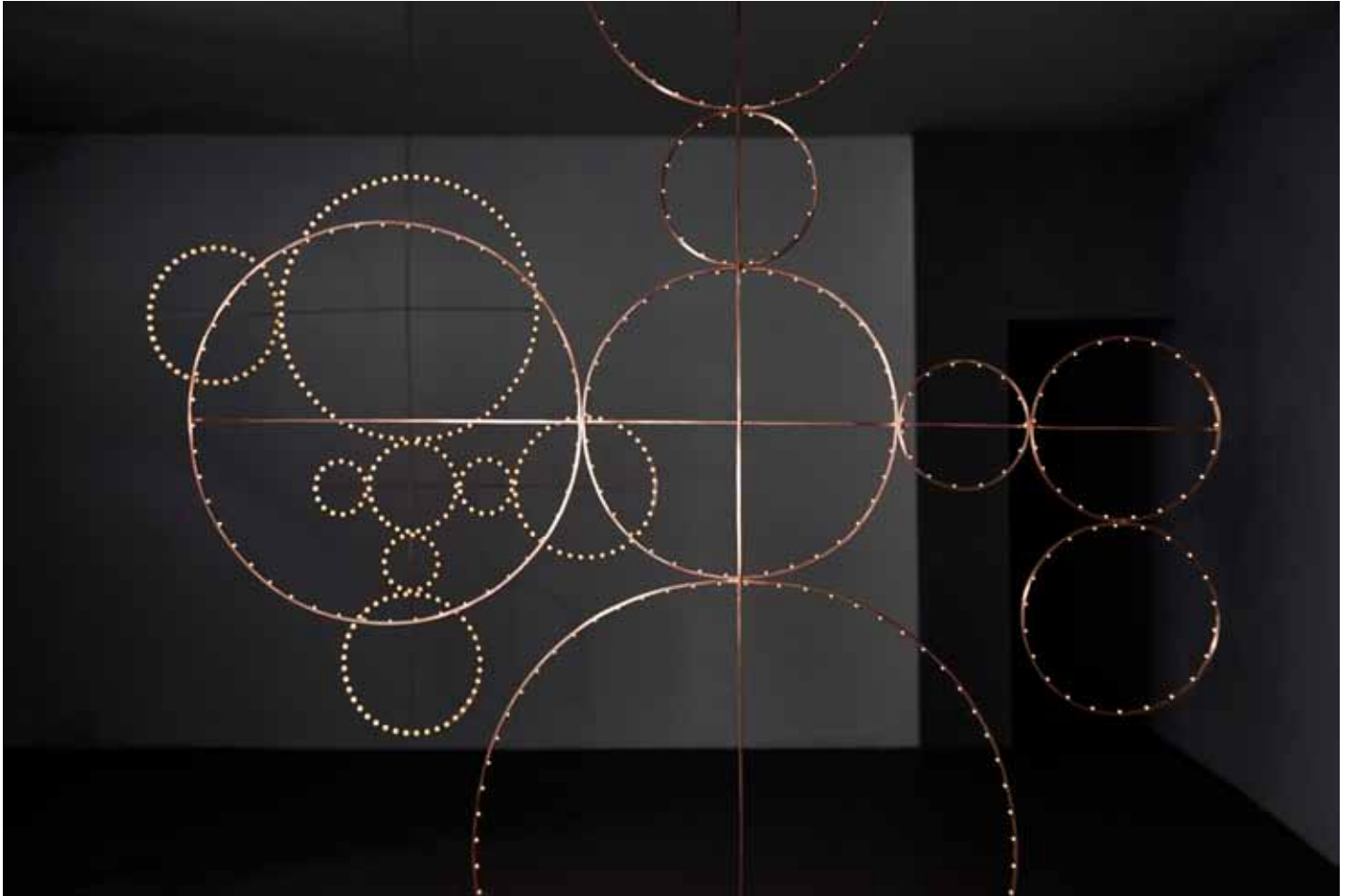

## Luminarie Santamaria 2

---

### Luminarie Santamaria 2

Hand Made in Italy

Dimensions:

Light: 2340 x 1350 mm

Materials: Steel, copper finish, micro LEDs





## Club Chair

Design: Glen Baghurst



## Club Chair

Hand Made in Sweden

Dimensions:

Chair: 550 x 710 x 700 mm

Materials: Leather, powder coated iron, iron fixings

Fashion designers dress one common frame in various ways. The leather has been bent and draped over both straight and curved shapes to create depth and volume to the chair. English saddlery has been a major inspiration in developing the hardware and shape of the dress on this frame.



[www.matterofstuff.com](http://www.matterofstuff.com) / [info@matterofstuff.com](mailto:info@matterofstuff.com)



Marque'  
Design: Alessandro Zambelli



The collection by Alessandro Zambelli comprises a series of storage furniture that include a small cabinet, a dry bar, a console and a coffee table, where the metal inlays remind of those traditionally found in Art Deco wooden furniture, adding a new element of character and prestige. The linear essentiality of the forms, which is reflected in each element of the collection, is enriched by the presence of precious superficial decors that are juxtaposed through inlays: small metal oxidised plates animate the surface of each storage element with their refined alternation of delicate geometrical motifs. The oxidation process brings a unique mutation of the surface itself, enriched by a whole variety of shades and gradation.





Marque'  
Dry Bar



[www.matterofstuff.com](http://www.matterofstuff.com) / [info@matterofstuff.com](mailto:info@matterofstuff.com)





---

## Marque' Dry Bar

Hand Made in Italy

Dimensions:

Console Bar: 410 W x 360 D x 1400 H (mm)

Materials: Metal inlays (Patinated Brass, Blackodized iron, Oxidized Copper), Black MDF, Velvet





Marque'  
Console



[www.matterofstuff.com](http://www.matterofstuff.com) / [info@matterofstuff.com](mailto:info@matterofstuff.com)

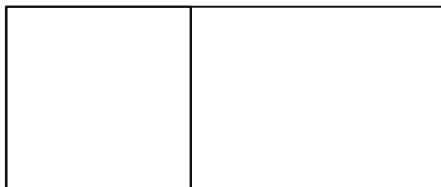
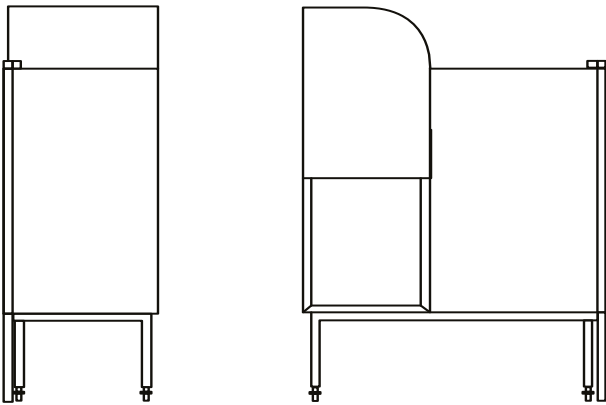

## Marque' Console

Hand Made in Italy

Dimensions:

Dry Bar: 410 W x 360 D x 1400 H (mm)

Materials: Metal inlays (Patinated Brass, Blacko-dized iron, Oxidized Copper), Black MDF, Velvet



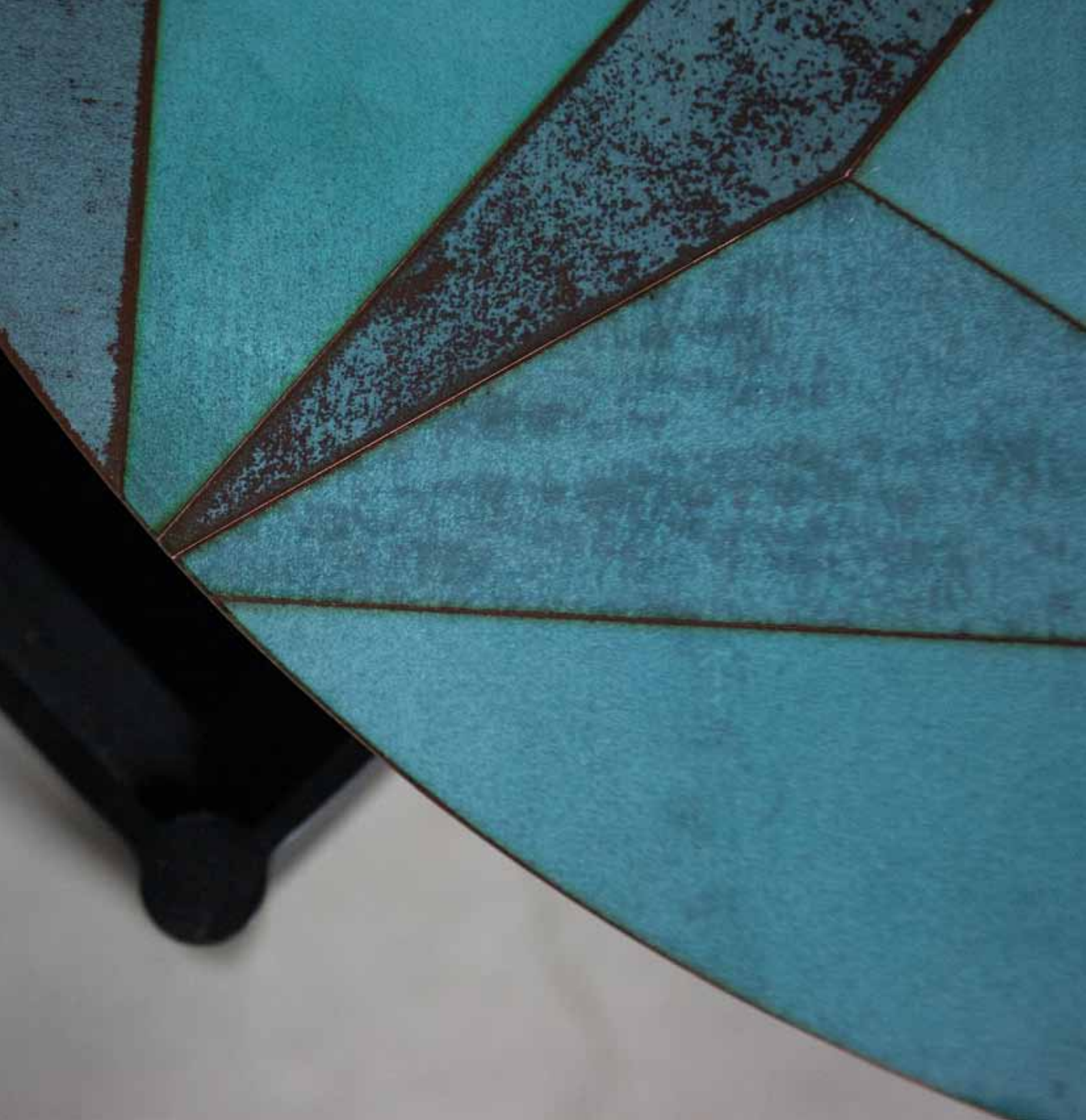

Marque'  
Coffee table



[www.matterofstuff.com](http://www.matterofstuff.com) / [info@matterofstuff.com](mailto:info@matterofstuff.com)

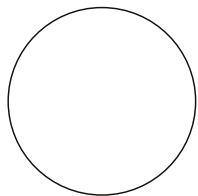
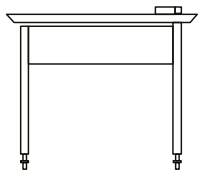
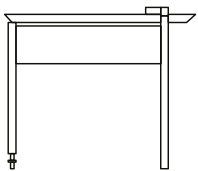

---

## Marque' Coffee Table

Hand Made in Italy

Dimensions:

Coffee Table: Diameter 400, H 400 (mm)

Materials: Metal inlays (Patinated Brass, Blacko-  
dized iron, Oxidized Copper), Black MDF, Velvet



[www.matterofstuff.com](http://www.matterofstuff.com) / [info@matterofstuff.com](mailto:info@matterofstuff.com)



Echo  
Design: Uufie

[www.matterofstuff.com](http://www.matterofstuff.com) / [info@matterofstuff.com](mailto:info@matterofstuff.com)



---

The “echo” table pushes the material limits of metal and wood to imagine an intangible reality. The grain of wood tells its history, and by using a technique of exposing the hardwood (season of winter) and embedded metal into the lines of the softwood (season of summer), each growth creates an elusive boundary between the two materials.

The objectivity further enhanced by the lightness and thinness in the profile of both materials. Beauty and inspiration are found all around us. The table legs reference the shape generated by the spilling of water.

The variation in the shapes of the table top resembles that of stones organically formed by sea current. Enacting the activity and motion which would happen around a table. The colours allude to the subtle shades of a sunrise, created in three metal: aluminium, copper, and brass.



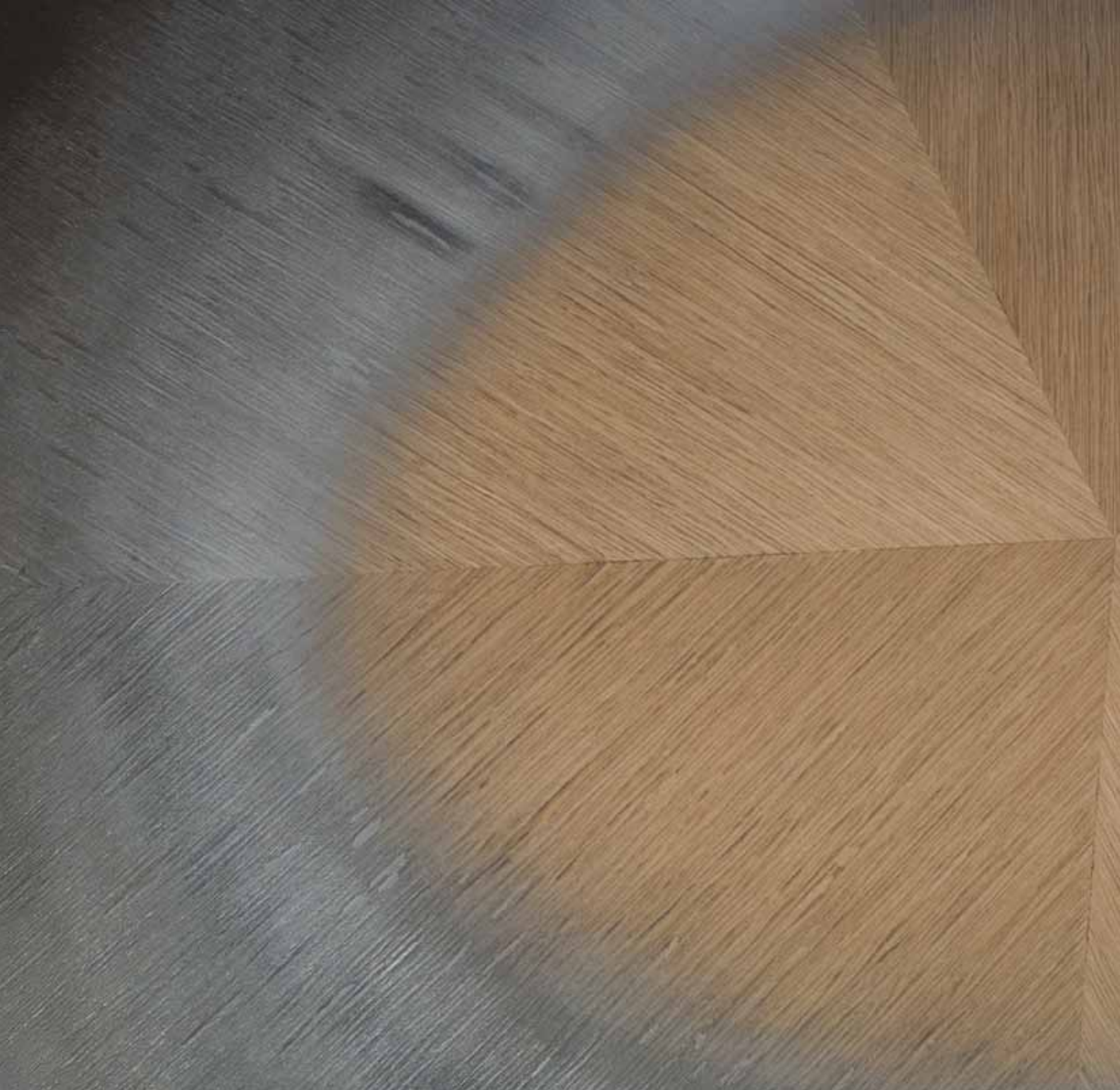

# Echo

## Large Dining Table





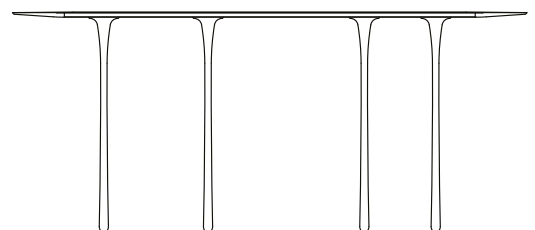
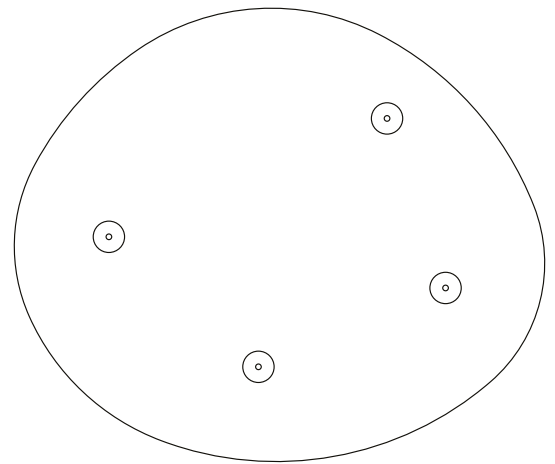

## Echo

### (Large Dining Table)

Hand Made in Italy

Dimension:

Large Dining Table: 1445 x 1695 (mm)

Materials: Stainless steel, wood, liquid metal (aluminium, copper, and brass)





Echo  
Medium Side Table



[www.matterofstuff.com](http://www.matterofstuff.com) / [info@matterofstuff.com](mailto:info@matterofstuff.com)

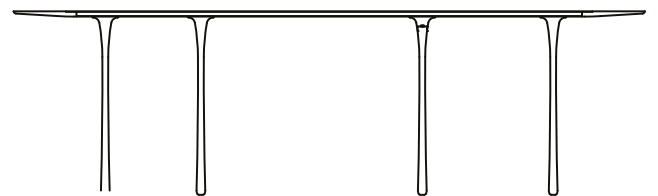
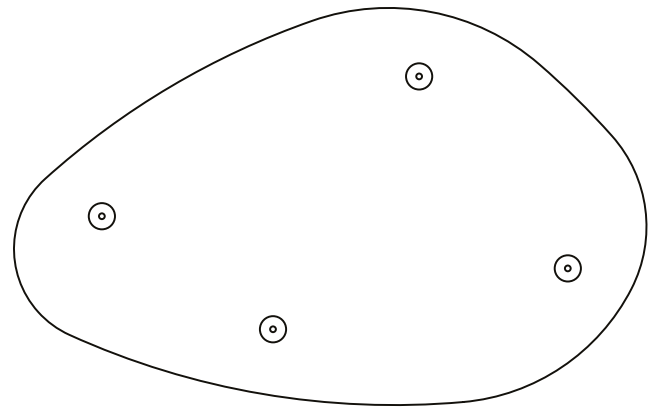

---

## Echo

### (Medium Side Table)

Hand Made in Italy

Dimension:

Medium Side Table: 1205 x 760 (mm)

Materials: Stainless steel, wood, liquid metal  
(aluminium, copper, and brass)



# Echo

Small Coffe Table



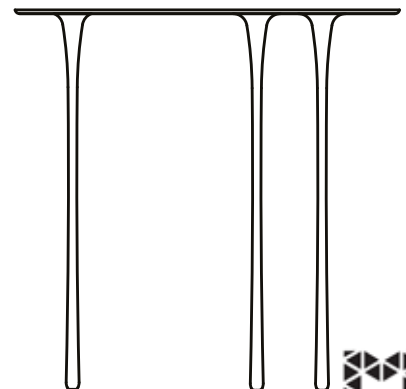
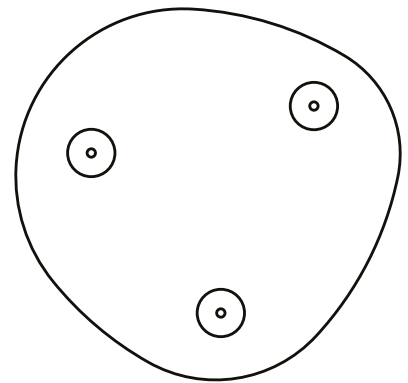

## Echo (Small Coffee Table)

Hand Made in Italy

Dimension:

Small Coffee Table: 505 x 490 (mm)

Materials: Stainless steel, wood, liquid metal  
(aluminium, copper, and brass)





Feather  
Design: Tomas Libertiny

[www.matterofstuff.com](http://www.matterofstuff.com) / [info@matterofstuff.com](mailto:info@matterofstuff.com)

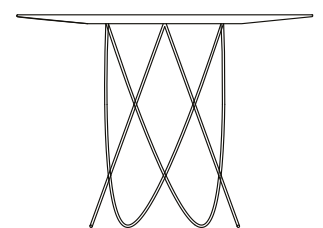
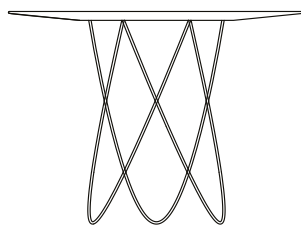
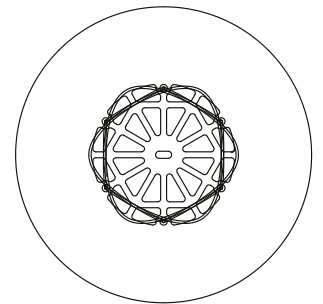
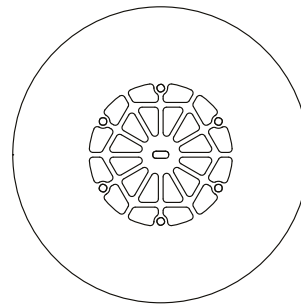

## Feather

Hand Made in Italy

Dimensions:

Dining table: 1000 Dia (mm)

Materials: Bianco Carrara Marble, CNC/hand carved

Marble is immensely rich material loaded with symbolic value. The challenge for Feather table is to explore the limitations of structural and poetic qualities of marble.





**Lithosphere**  
Design: Studio deFORM





---

## Lithosphere

Dimension:

Coffee Table: 800x300x370 (mm)

Materials: Caesar Black, Breccia Dark,  
Breccia Light, Veined White



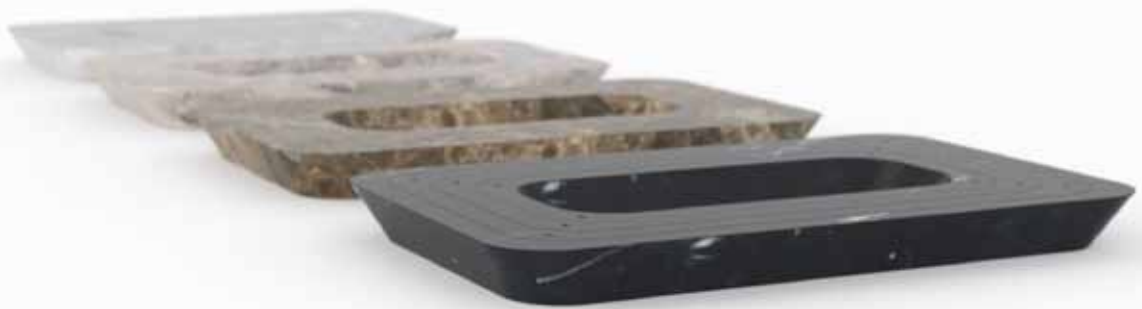



---

Design by Studio deFORM

The design of the Lithosphere Coffee Table takes its inspiration from the different layers of the Earth's crust and upper mantle. The table juxtaposes four stone slabs sourced from specific locations in Italy. The slabs are divided into four concentric elements, these nestle seamlessly inside each other, as in a Matryoshka. The sixteen elements can then be separated and stacked in differing combinations, producing four material variations of the table. The design was carefully considered to maximise the use of each slab. By intermingling the four stones, variety is created, whilst simultaneously minimising waste.





**Coulee**  
Design: Nina Cho



[www.matterofstuff.com](http://www.matterofstuff.com) / [info@matterofstuff.com](mailto:info@matterofstuff.com)



---

## Coulee

Hand Made in Italy

Dimensions:

Side Table: W 490 D 380 H 450 (mm)

Materials: Bardiglio nuvolato, Bianco Carrara Marble

The distinguishing feature of the Coulee side table is the subtle recessed curve, that can be used as an organiser and container for displaying small goods, coins, cell phone, keys, flowers. Coulee uses two heavyweight pieces, creating a stable structure by joining complimenting geometry where the table becomes a singular mass/volume/sculpture.





The Veiled  
Design: Olga Bielawska



---

Design by Olga Bielawska

The Veiled is a collection of tables and trays made of marble with a graphical pattern inspired by an ancient statue. It experiments with the dichotomy between a silk and soft looking surface for a hard material like marble. The effect of light and dark-coloured marble in stripes is both graphic and illusional, as the pattern catches your eye and invites you to touch. The collection of tables combine contemporary techniques and aesthetics with the traditional way of making inlays.



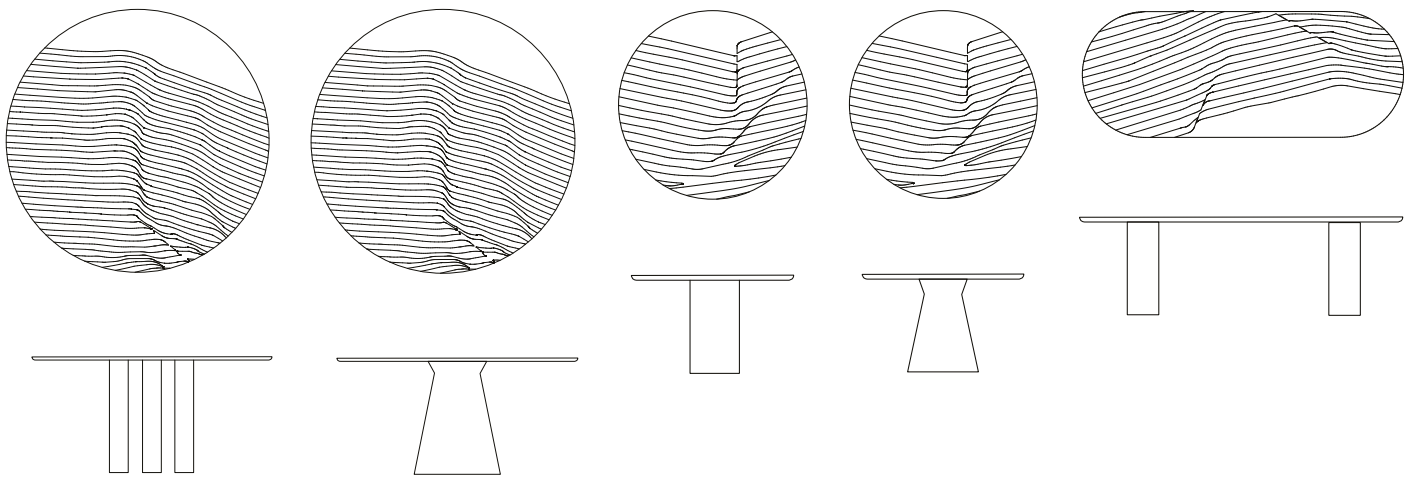

---

Hand Made in Italy

Dimensions:

Sidetable oval 1200x470x300 (mm)

Dining table: 1600 Dia, h750 (mm)

Sidetable round 700x700x350 (mm)

Materials: Bianco Carrara marble,  
Nero Marquinia Marble Inlays.









Remetaled  
Design: Tim Vanlier



---

Design by Tim Vanlier

Remetaled nesting table is a series of two tables, consisting a layering composition of different types of metal sheets. Layering brings depth in a object, offers room for surprise, and gives the metal an innovative materiality. By nesting metal sheets in a vertical direction, a new layered texture originates, giving the metal a new materiality.

## Remetaled

Hand Made in Italy

Dimension:

Large Table: Large D600 x H388mm (mm)

Small Table: D450 x H330mm (mm)

Materials: Copper, Aluminium,  
Steel, Liquid Metal



[www.matterofstuff.com](http://www.matterofstuff.com) / [info@matterofstuff.com](mailto:info@matterofstuff.com)



**Mirrored**  
Design: Tim Vanlier

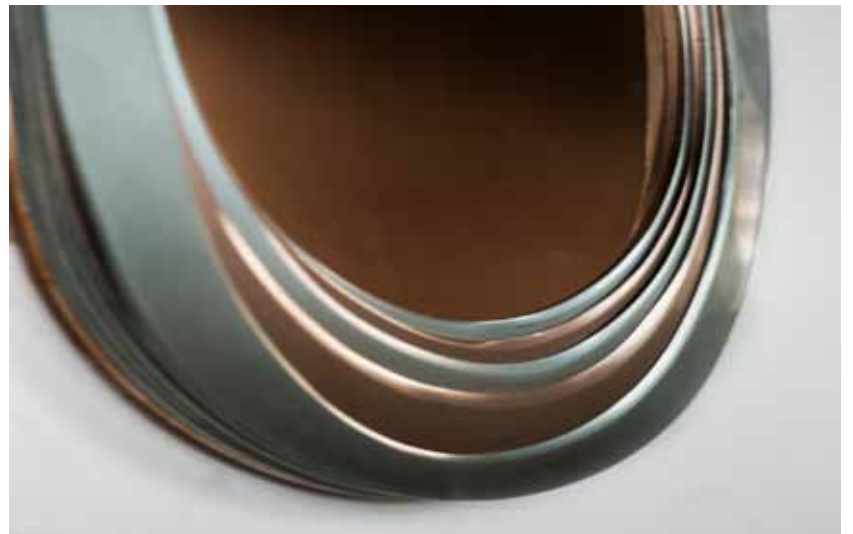

---

## Mirrored

Design by Tim Vanlier

Mirrored are reflective objects constructed out of different types of metal layered together to create an organic feel. Highly polished steel or copper gives high reflectivity to the last layer, creating a mirror effect.

## Mirrored

Hand Made in Italy

Dimensions:

Large Mirror: H1800 x B600 (mm)

Medium Mirror: H650 x B400 (mm)

Small Mirror: H250 x B160 (mm)

Materials: Copper, Aluminium, Polished Steel





Marble Cone  
Design: Ariel Zuckerman



---

## Marble Cone

Hand Made in Italy

Dimensions:

Light: H300, B20 (mm)

Material: Blue Macaube Marble/ Bianco di Carrara marble/ Nero Marquinia marble

Design by Ariel Zuckerman

The marble cone light can be used as a single element, or by adding more units the modular structure, it can evolve and blossom.



[www.matterofstuff.com](http://www.matterofstuff.com) / [info@matterofstuff.com](mailto:info@matterofstuff.com)



**Asymmetric**  
Design: Ariel Zuckerman





---

Design by Ariel Zuckerman  
Asymmetric light is a non symmetric metal lighting fixture with unique different finishes, thus creating series of pendant lamps that have a different look from each view.

## Asymmetric

Hand Made in Italy

Dimensions :

Light: 620, 350, H250 (mm)

Materials: Galvanized stainless steel





## NODA Sculptural Trivets

Design: Karsan Haval, Lara Chapman, Phoebe Morris

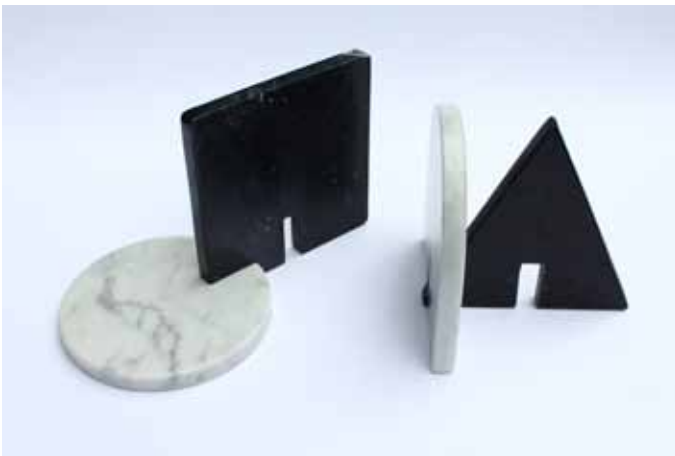

---

## NODA

Hand Made in Italy

Dimensions:

Trivets: 180 x 180 x 18 mm

Materials: White Carrara & Nero Marquina  
Marble

NODA pays homage to the historic use of marble as a medium for sculptors. Noda is a set of four trivets that, in their downtime, create modern, small-scale sculptures for the dining table; providing a functional, decorative and interactive element in one product. When not in use, the trivets encourage the user to play with form and balance to create their own interesting centerpiece.





Deskcape  
Design: Arturo Soto, Natalie Pichler



---

## Deskcape

Hand Made in Italy

Dimensions:

Deskcape: 212 H, 80 D mm

Materials: Nero Marquina Marble, brass

The place where people work says a lot about their character. Whether they are working there or not, the objects on the desk will always represent and say something about the owner. Deskcape, a desktop organiser that creates a unique and sophisticated atmosphere.





Svelata  
Design: Moreno Ratti

# Svelata

Hand Made in Italy

Dimensions:

Small: H15 (mm)

Large: H34 (mm)

Material: Bianco di Carrara/ Nero di Carrara Marble



---

Design by Moreno Ratti

Svelata is a serie of hand-carved vases made from a single block of Carrara Marble.

The idea comes from the desire to create a timeless flower pot, which is classic and modern at the same time, as marble itself. The relationship between the modern and classical forms is revealed thanks to the artisan who hand-carves the piece. Each piece is unique.





Curvy  
Design: Ariel Zuckerman





---

Design by Ariel Zuckerman  
Curvy candleholder uses different types of marbles and shapes to create a unique composition.  
By turning the candleholder 180 degrees, the user will experience a different composition.

**Curvy**  
Hand Made in Italy  
Dimensions:  
Candleholder: L 300, D 55 (mm)  
Materials: Blue Macaube Marble, Bianco di Carrara marble, Nero Marquinia marble





**Full Bowl**  
Design: Sebastian Bergne

# Full Bowl

Handmade in Italy

Dimensions:

Bowl: 70H, 350D mm

Materials: Statuario Marble.



---

Design by Sebastian Bergne

Full bowls are on the point of overflowing. The precious marble is crafted into a form that makes a liquid form solid. They function normally as bowls only sharing the expected volume with the object itself. This makes them ideal for displaying small amounts of beautiful food or objects.

Each Full bowl is hand turned in Italy from marble. Variations in grain and colouring make each bowl unique.





Flower Vessel

Wine Cooler

Design: Guglielmo Maggini



## Flower Vessel

---

The object is multifunctional and allows the user to play with it and its own function: it can be used as tableware sculpture, a glass holder as well as a vase when the wine bottle is not in it.

The marble discs can slide off from the brass bar and reassembled by people in different ways, therefore everyone can create their own unique piece playing with the nuances and the patterns inherent in every block of marble.

Handmade in Carrara, Italy





# Wine Cooler

---

Materials: Carrara Marble.

The project takes advantages from the natural thermic qualities of marble and inspiration from the long-held tradition that Carrara marble has with food.

The product can maximise the use of marble wastes as each piece comes straight from the marble coring cylinders discarded by the industrial productions.







# The Wave

## Fruit Holder

Design: Kai Hua Tsa

---

Materials: Carrara Marble.

The fruit bowl is assembled by simple shape of marble pieces with abstract composition, which creates a feeling of natural aesthetic.

The idea is born from using simple principle to explore the marble quarry.





# BRUNELLO DI MONTALCINO 2011

Design: Alessandro Zambelli,  
Nina Cho, Olga Bielawska,  
Tim Vanlier, Tomas Gabzdil  
Libertiny, UUfie

---

## BRUNELLO DI MONTALCINO 2011

Banfi Wine & Design is an artistic project that celebrates the exclusive character of Banfi's signature wine: the Brunello di Montalcino Castello Banfi.

The project is born from the collaboration of Banfi with MOS for the first edition of "MOS Designer Residencies" where six designers (Alessandro Zambelli, Nina Cho, Olga Bielawska, Tim Vanlier, Tomas Gabzdil Libertiny, UUfie) were called to design a wine label for a special limited edition of Brunello di Montalcino Castello Banfi 2011.

The project involves the production of customized wooden boxes, each containing six numbered bottles of 750 ml., with a label designed by each artist.

The designers were inspired by their personal reinterpretation of the official label of Castello Banfi Brunello di Montalcino, driven in their work by the six pillars on which is founded the Banfi philosophy: Territory, Tradition, Innovation, Quality, Passion and Sustainability.

Product Details:

6 bottles of Brunello di Montalcino 2011 DOCG





Alessandro Zambelli

---

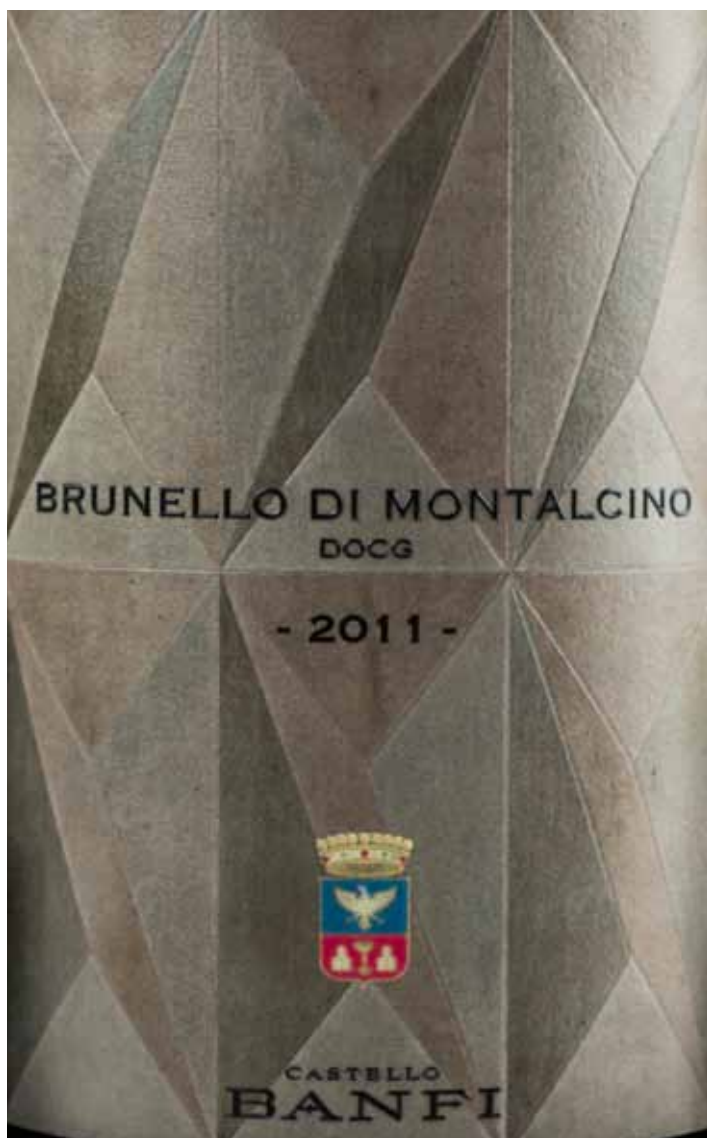

Nina Cho



Olga Bielawska

---

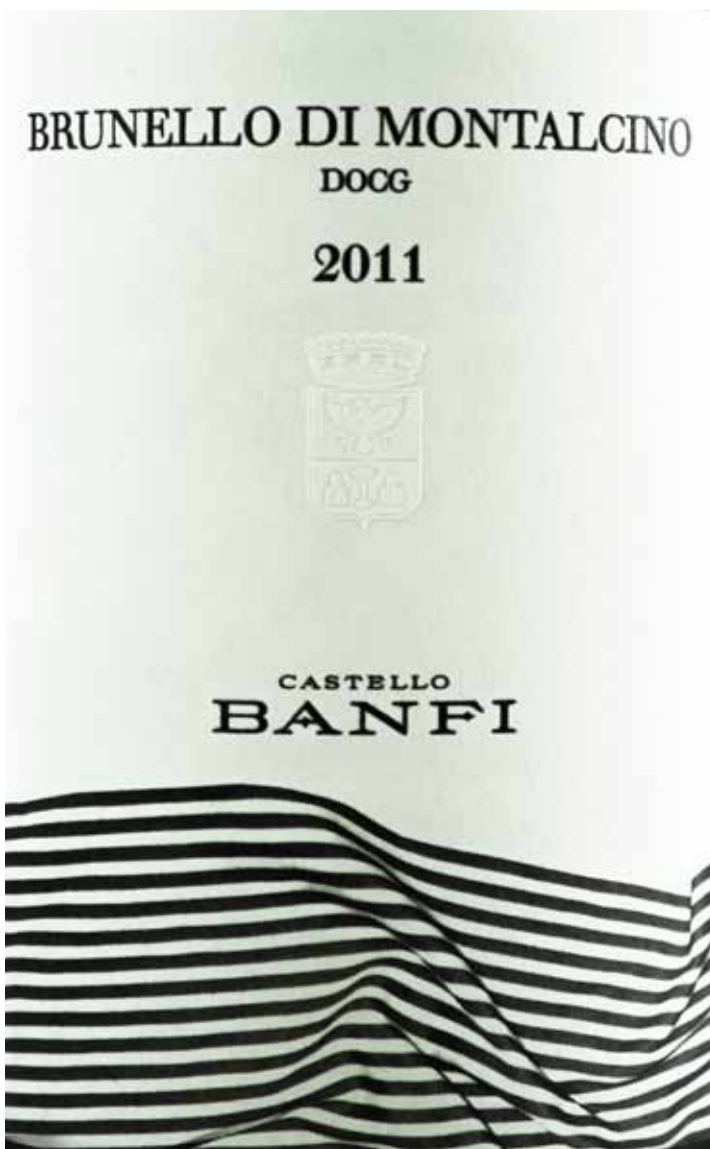

Tim Vanlier

---



Tomas Gabzdil Libertiny



Uufie

---







[www.matterofstuff.com](http://www.matterofstuff.com)  
[info@matterofstuff.com](mailto:info@matterofstuff.com)

Matter of Stuff Limited  
Flat 8, 241-243 Hackney Road, E28NA, London  
Registered in England and Wales No: 8878002  
VAT number No: 197 5146 70  
Simona Auteri: 0044 (0)7712680221  
Sofia Steffenoni: 0044 (0)7446858423