

DURAME[®]



CONTEMPORARY WOOD
HOME COLLECTION

CONTEMPORARY WOOD
HOME COLLECTION

2018

mobili e complementi d'arredo

DURAME[®]

Durame è il risultato dell'unione tra la grande passione per la lavorazione del legno, tramandata da generazioni, e il desiderio di dare forma a idee e pensieri nuovi, aggiornati e al passato coi tempi. Ecco allora una collezione dalle connotazioni sperimentali, composta da oggetti unici, carichi di significato, ognuno con una personalità precisa e distinta, che esprimono a pieno i valori dell'alto artigianato italiano e le infinite potenzialità del più antico materiale da costruzione.

Durame is the result of the union between the great passion for wood carving, transmitted from age to age, and the desire to shape new and fresh ideas and thoughts. So here it is, a series of unique objects characterized by experimental and meaningful connotations. Each one of them has a different meaning and a precise personality that fully expresses the values of the noble Italian craftsmanship and the limitless potential of the oldest building material.

contemporary wood

La cura del particolare, la grande abilità artigiana, la ricerca e la valorizzazione della materia sono state componenti di rilievo nella progettazione e realizzazione dei pezzi che compongono la collezione **Durame**, creati avvalendosi della collaborazione di designer dal gusto colto e raffinato.

La gamma include contenitori, sedute, tavoli e oggettistica funzionale; tutti elementi dal carattere contemporaneo, accomunati dalla forte presenza del legno, espressione di naturalità e bellezza, ma caratterizzati ognuno da uno stile personale, eclettico ed inusuale, grazie a lavorazioni che esaltano le sfumature estetiche del legno stesso, ad accostamenti inediti di materiali diversi e alla ricerca del dettaglio e della finitura non scontata.

*The care for the detail, the great handmade skill, the research and the enhancement of the material were important elements during the planning and the creation of the articles that are part of the **Durame** collection. These pieces were created in collaboration with designers with a refined and cultured taste. The collection includes containers, seats, tables and accessories; all these elements have a contemporary personality and are characterised by the strong presence of wood. Thanks to the manufacturing that intensifies wood's aesthetic shades and thanks to the unusual pulling together of different materials, every single piece expresses authenticity, beauty and has its own eclectic and unusual style. The search for the detail and for the unexpected finishing, makes our products even more valuable.*

DURAME®





“ Guardate nel profondo della natura, e allora capirete meglio tutto. ”
Albert Einstein

*“Look deep into nature,
and then you will understand
everything better.”*
Albert Einstein

DURAME®

CONTENITORI

STORAGE UNITS

SINGOLO

design: Maurizio Di Lauro

LIBRERIA

Dimensioni:

L 78 x P 16 x H 104 cm (S)
L 78 x P 16 x H 210 cm (M)
L 78 x P 16 x H 240 cm (L)
L 78 x P 16 x H 266 cm (XL)
L 78 x P 16 x H 296 cm (XXL)

Materiali:

Legno massello di rovere / rovere tinto
nero / noce canaletto;
Ottone satinato

Una libreria che può essere utilizzata
a parete o per dividere due ambienti.
Leggerezza e matericità si fondono
per dare vita ad un oggetto che va oltre
il semplice mobile in cui riporre dei libri:
SINGOLO è una sorta di facciata
architettonica, una boiserie
tridimensionale.



BOOKCASE

Dimensions:

L 78 x W 16 x H 104 cm (S)
L 78 x W 16 x H 210 cm (M)
L 78 x W 16 x H 240 cm (L)
L 78 x W 16 x H 266 cm (XL)
L 78 x W 16 x H 296 cm (XXL)

Materials:

Solid oak wood / Black stained solid oak
wood / Solid walnut wood;
Satin-finish brass

*A bookcase that can be placed against
the wall or to divide two areas.
Lightness and materiality melt to create
an object that is much more than a
simple furniture for storing books.
SINGOLO is a sort of an architectural
facade, a three-dimensional boiserie.*

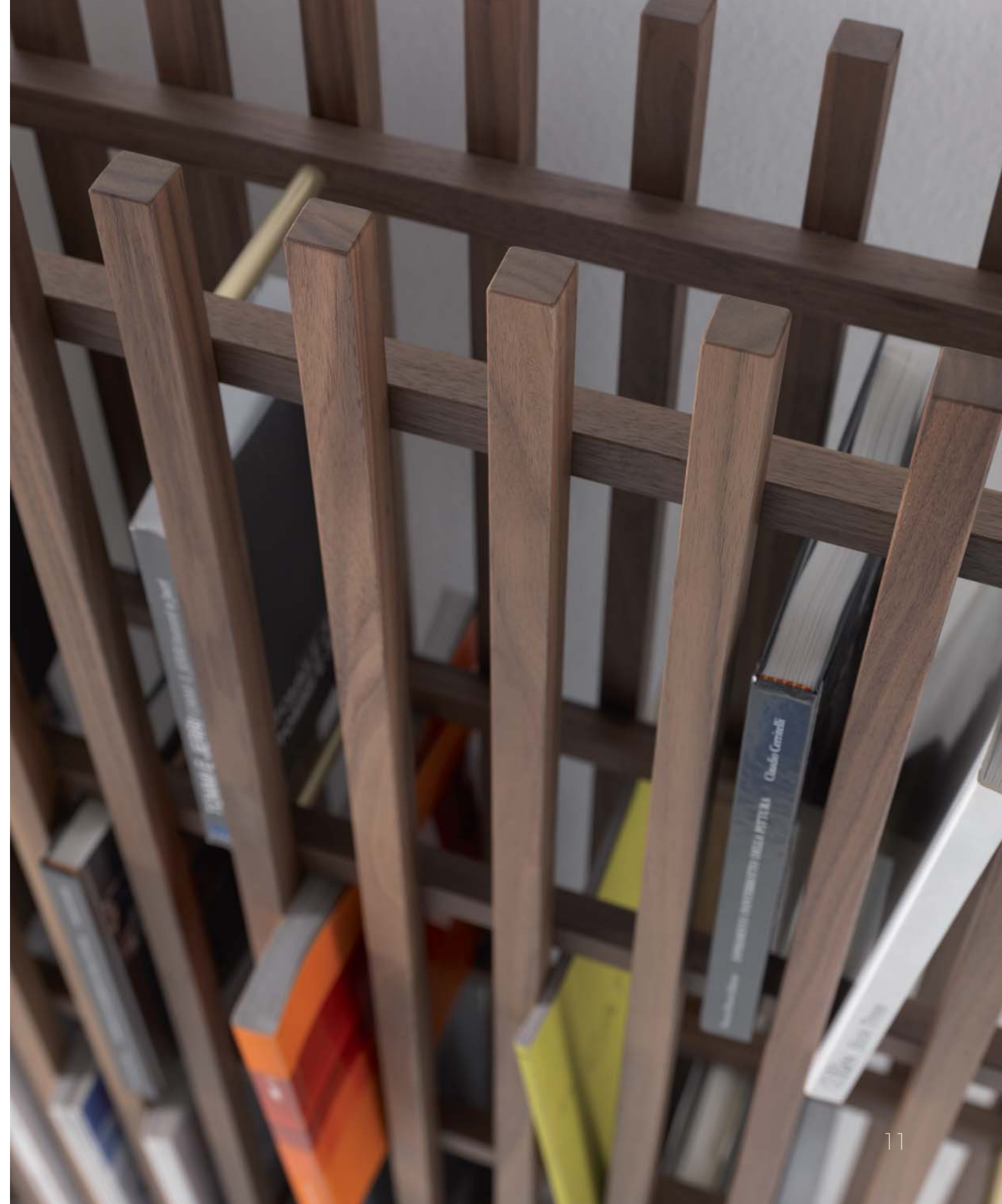





CRAB

design: Maurizio Di Lauro



MOBILE CONTENITORE

Dimensioni:

L 174 x P 55 x H 82 cm
L 174 x P 55 x H 73 cm
L 200 x P 55 x H 82 cm
L 200 x P 55 x H 73 cm

Materiali:

Legno massello e tranciato di
palissandro / rovere / noce canaletto;
Anta in ottone.

Crab madia è un omaggio al design
italiano degli anni '50.

Crab è costituita da una struttura
portante a vista in legno massello,
ruotabile per avere altezze differenti.
Il volume contenitore è caratterizzato
da ante che si differenziano nel
disegno, nei materiali e nei dettagli.

CABINET

Dimensions:

L 174 x W 55 x H 82 cm
L 174 x W 55 x H 73 cm
L 200 x W 55 x H 82 cm
L 200 x W 55 x H 73 cm

Materials:

Solid rosewood and veneer wood /
Solid oak and veneer wood / Solid
walnut and veneer wood,
Door in brass.

Crab Madia is a tribute to the Italian
design of the '50.

It consists of a visible bearing structure
in solid wood that can be rotated to
get different heights.
The internal volume is featured by
doors of different design, materials and
details.







CRAB ALTO

design: Maurizio Di Lauro

MADIA

Dimensioni:

L 105 x P 48 x H 162 (basso)
L 105 x P 48 x H 171,5 cm (alto)

Materiali:

Legno massello e tranciato di
palissandro / rovere / noce canaletto;
Cassetto in ottone.

Crab credenza è caratterizzata da una struttura portante a vista in legno massello, ruotabile per dare altezze differenti.

Il volume contenitore si sviluppa attraverso quattro ante ed un cassetto, in cui vi è un'alternanza nel disegno, nei materiali e nei dettagli.

SIDEBOARD

Dimensioni:

L 105 x W 48 x H 162 cm (low)
L 105 x W 48 x H 171,5 cm (High)

Materiali:

Solid rosewood and veneer wood /
Solid oak and veneer wood / Solid
walnut and veneer wood,
Drawer in brass.

Crab Credenza consists of a visible bearing structure in solid wood that can be rotated to get different heights. The internal volume is composed by four doors and a drawer, where you can find different design, materials and details.



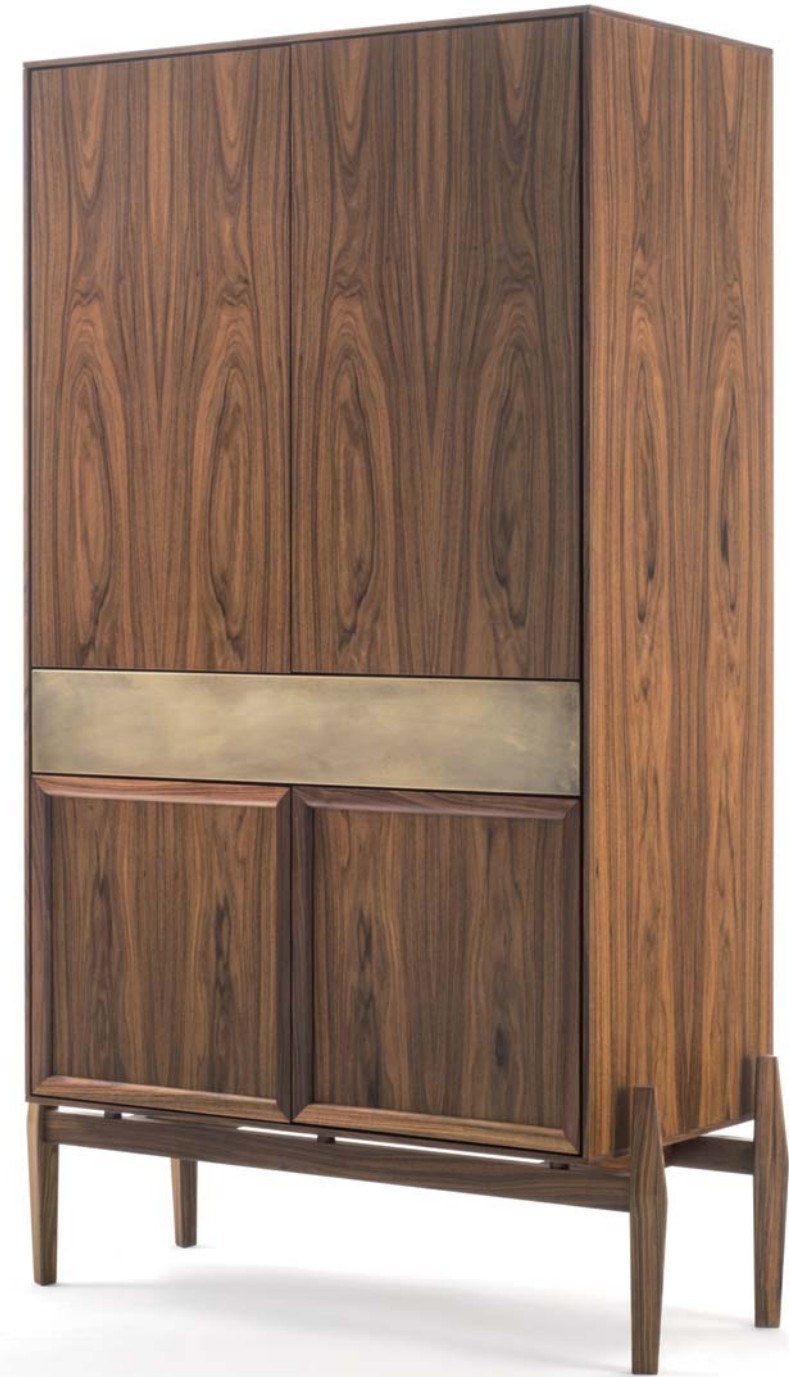

BREATHE

design: Studio BAAG

MOBILE CONTENITORE

Dimensioni:
L 80 x P 40 x H 156 cm

Materiali:
Legno massello e tranciato di rovere /
castagno / noce canaletto;
Ferro laccato: blu / verde / bronzato
(altri colori a richiesta)

Un mobile contenitore con
una superficie epidermica. Pori che
traspirano una sensualità velata, quasi
nascosta. Un invito ad un'esperienza
tattile ed esplorativa. Punti di colore e
dettagli sobri e raffinati decorano un
volume semplice ma scultoreo.



CABINET

Dimensions:
L 80 x W 40 x H 156 cm

Materials:
Solid oak and veneer wood /
solid walnut and veneer wood /
solid chestnut and veneer wood;
Lacquered metal: blue / green /
bronzed (other colors on request)

*A cabinet with an epidermal surface.
Pores that transpire a veiled sensuality.
An invitation to a tactile and
exploratory experience. Points of colour
and refined details adorn a simple but
sculptural volume.*



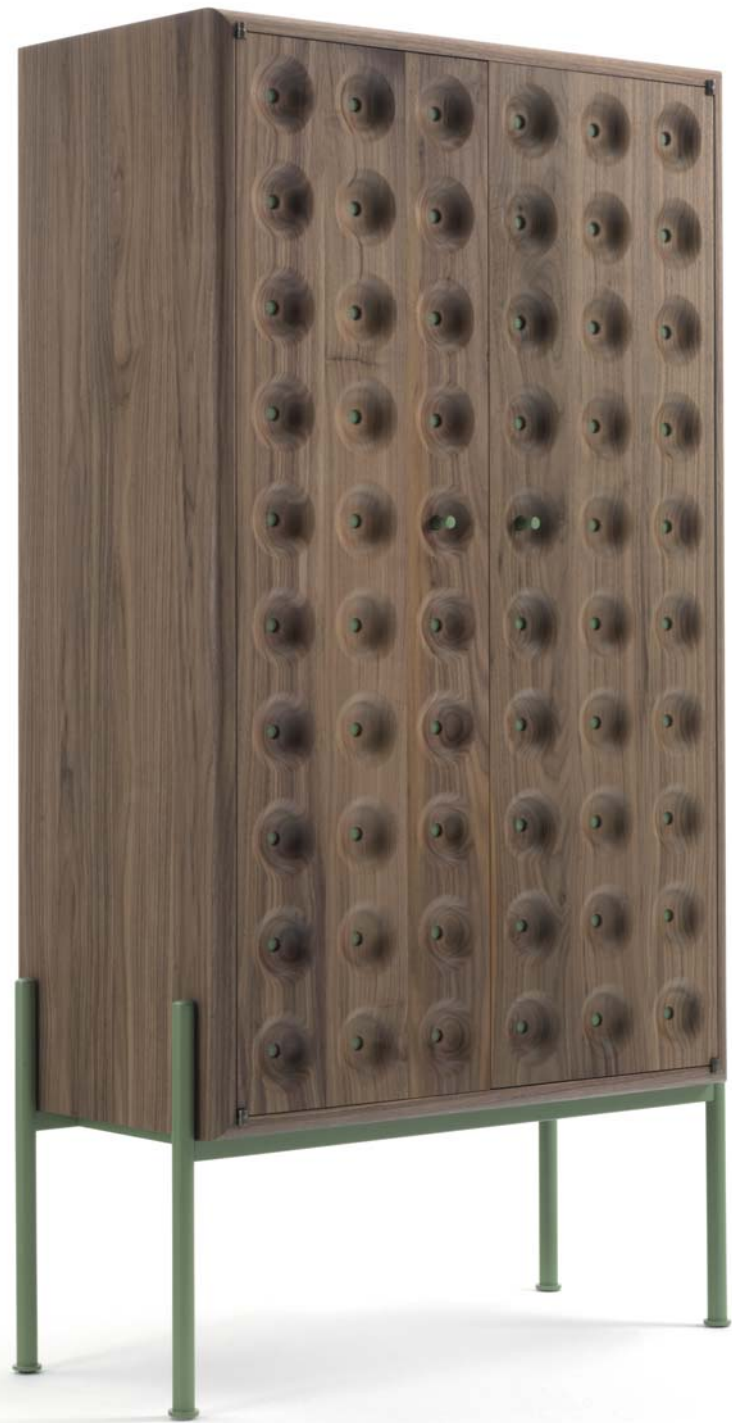



LIPSTICK

design: Michela Catalano / Andrea Gerosa

MOBILE CONTENITORE

Dimensioni:
L 65 x P 46 x H 185 cm

Materiali:
Parte interna: legno di rovere / olmo /
noce canaletto;
Parte esterna: laccatura: blu /
bordeaux (altri colori a richiesta)

Sculptura, totem, mobile bar.
Lipstick è puro, essenziale,
ellittico, ironico.
All'interno rivela la sua funzione prima
celata, con ripiani in cristallo extrachiaro,
l'illuminazione a led e il comodo vassoio
estraibile.
Disponibile nei colori laccati lucidi,
satinati o in essenza naturale, è
impreziosito dai raffinati dettagli in ottone
opaco e dalle ante ricurve.



CABINET

Dimensions:
L 65 x W 46 x H 185 cm

Materials:
*Oak wood /
Elm wood / Walnut wood;
Lacquered blue / bordeaux
(other colors on request)*

Sculpture, totem, bar cabinet.
Lipstick is pure, essential, ironic.
Inside you can find extra-clear glass
shelves, LED lighting and a convenient
removable tray. It's also enhanced
by refined details of opaque brass and
by curved doors.
It's available in different types of colors
(varnished, satinized or in natural
essence).







ELLA

design: Federica Biasi



MADIA

Dimensioni:
L 118 x P 46 x H 97,5 cm
L 118 x P 49 x H 97,5 cm (Bifacciale)

Materiali:
Legno massello e tranciato di rovere /
Ottone bronzato;
Legno massello e tranciato di noce
canaletto / Ottone satinato;
Ripiani interni in legno o cristallo;
Vassoio in legno estraibile a richiesta

Una madia caratterizzata da un chiaro
rimando al mondo sartoriale:
la lavorazione a fresatura su legno, crea
un effetto plissettato con andamento
graduale sui pannelli che ne
compongono le superfici verticali.

SIDEBOARD

Dimensioni:
L 118 x W 46 x H 97,5 cm
L 118 x W 49 x H 97,5 cm (Bifacial)

Materiali:
Solid oak and veneer wood /
Bronzed brass;
Solid walnut and veneer wood /
Satin-finish brass;
Wood or crystal internal shelves;
Pull-out wood tray on request

A sideboard characterized by a
clear reference to the sartorial reality:
the milling machine makes the timber
look gradually pleated on the panels
which compose its vertical
surfaces.





SIPARIO

design: Cristina Celestino

MOBILI CONTENITORI

Dimensioni:
Cabinet basso L 140 x P 45 x H 94 cm
Cabinet alto L 80 x P 45 x H 160

Materiali:
Legno massello e tranciato di rovere /
noce canaletto;
Ripiano interno in cristallo;
Frange tripolino verde bosco /
verde cipresso / pervinca / rosa antico
e possibili colori a richiesta

SIPARIO rappresenta la messa in scena
progettuale dell'atmosfera che si
respira calcando il palcoscenico dei
teatri storici.
L'ispirazione nasce da uno studio del
teatro all'italiana:
emiciclo ligneo, quinte prospettiche e
scena profonda.



CABINETS

Dimensions:
Low Cabinet L 140 x W 45 x H 94 cm
High Cabinet L 80 x W 45 x H 160

Materials:
Oak wood / walnut wood;
Crystal internal shelf;
Tripoline fringes forest green / cypress
green / periwinkle / antique pink and
other colours on demand;

SIPARIO represents the planning
mise-en-scène that can breathe
treading the boards of an historical
theatre.
The inspiration arises from a study
about Italian theatres:
a wooden semi cycle, perspectival
off-stages and a deep scenery.





GROW

design: Paolo Salvadè

LIBRERIA

Dimensioni:
L 55 x P 55 x H 220 cm

Materiali:
Legno massello di rovere /
Ferro cerato;
Legno massello di noce canaletto /
Ferro bronzato;
Legno massello di larice /
Ferro bronzato

Una fusione perfetta di due materiali;
una forma sagomata in legno
massello e alzatine metalliche
compongono un totem scultoreo
con sviluppo verticale,
dove esporre oggetti o riporre libri.



BOOKCASE

Dimensioni:
L 55 x P 55 x H 220 cm

Materiali:
Solid oak wood / Waxed metal;
Solid walnut wood /
Bronzed metal;
Solid larch wood / Bronzed metal

*A perfect fusion of two materials;
a solid wood contoured shape and
metal backsplashes compose a
sculptural totem with a vertical
development, where exhibiting objects
or storing books.*





CAMINETTO

design: Dmitry Kozinenko

MOBILE CONTENITORE

Dimensioni:
L 70 x P 45 x H 220 cm

Materiali:
Legno di rovere / rovere
tinto grigio / noce canaletto;
Fondale laccato rosso o naturale;
Ripiani interni in cristallo

Un'idea nata dal tentativo di osservare da un'angolazione diversa gli oggetti familiari che ci circondano. Un mobile contenitore luminoso che è metafora del focolare domestico.



CABINET

Dimensions:
L 70x W 45 x H 220 cm

Materials:
Oak wood / Grey stained oak wood /
Walnut wood;
Red or natural lacquered backcloth;
Crystal internal shelves

This idea has its roots in the purpose to look to everyday objects in a different way. A light cabinet that is a metaphor for the household.



ASTEROID

design: Dmitry Kozinenko

LIBRERIA

Dimensioni:
L 100 x P 40 x H 190 cm

Materiali:
Legno di rovere / noce canaletto;
Portavaso in legno trattato

Una libreria idealmente attraversata da un corpo estraneo caduto dall'alto che, prima di impattare con il suolo, ha creato nei ripiani dei fori che ne ricalcano la forma. Lo spazio ricavato consente di inserirvi una pianta da vaso o una scultura, da far convivere con libri e altri oggetti.

BOOKCASE

Dimensions:
L 100 x W 40 x H 190

Materials:
Oak wood / Walnut wood;
Reated wood vase holder

An unrelated object falls from the top and undergoes the library creating holes in the shelves before crushing on the floor. This idealistic movement produces a field where you can insert in the library a pot plant or a sculpture that can live with books or other items.





4x4Wood

design: Michele Barberio - XYZ FACTORY

MOBILE CONTENITORE

Dimensioni:
L 150 x P 50 x H 150 cm

Materiali:
Legno massello e tranciato di rovere /
noce canaletto;
Ante: laccate grigio / blu e possibili
(altri colori a richiesta)

Mobile multiforme composto da un contenitore laterale sinistro con ante verticali, a cui si affianca un vano a giorno stretto ed alto. A seguire, un blocco quadrato ripartito in quattro quadranti, su cui si muovono liberamente, come su una scacchiera, le due ante ribaltabili. Ecco dunque il risultato di 4x4 wood, ovvero 16 diversi modi di pensare e comporre la propria credenza.



CUPBOARD

Dimensions:
L 150 x W 50 x H 150 cm

Materials:
Solid oak and veneer wood /
Solid walnut and veneer wood;
Doors: Gray / blue varnished lacquer
(other colours on request)

This multiform cupboard consists of a container on the left side with a vertical door, flanked by a narrow and tall open compartment. Following, a square block divided into four parts, on which the two folding doors, that only partially close the cupboard, move freely, as if they were on a chessboard. This is the result of 4x4 wood, that is 16 different ways of thinking and composing your own cupboard.





THE EDGE

design: Studio BAAG & Uto Balmoral

PENSILE CONTENITORE

Dimensioni:
L 120 x P 35 x H 45 cm

Materiali:
Legno di rovere / noce canaletto /
betulla;
Fresate nei colori: verde / blu / rosso /
giallo / arancio / nero / grigio

Un mobile contenitore dai tratti grafici ed essenziali. Fresate lineari che si intensificano in prossimità dell'angolo, lo decorano e ne evidenziano il volume in modo tridimensionale e asimmetrico.

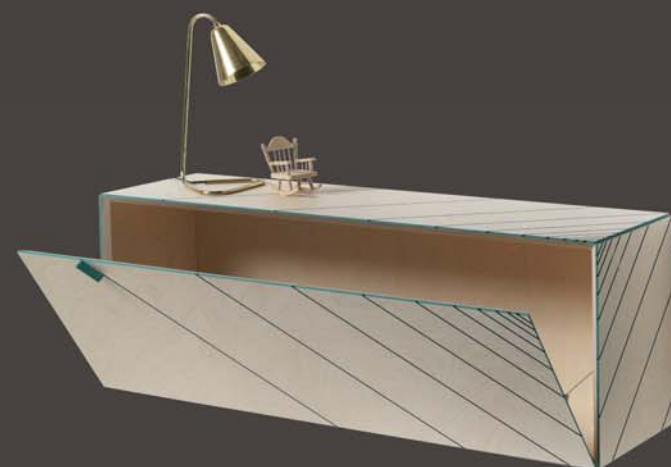

STORAGE UNIT

Dimensioni:
L 120 x W 35 x H 45 cm

Materiali:
Oak wood / walnut wood /
birch wood;
Millings: green / blue / red / yellow /
orange / black / grey

A cabinet with essential and graphic traits. Linear cuts that intensify in the proximity of the corner, decorate and highlight the piece in a tridimensional and asymmetrical way.

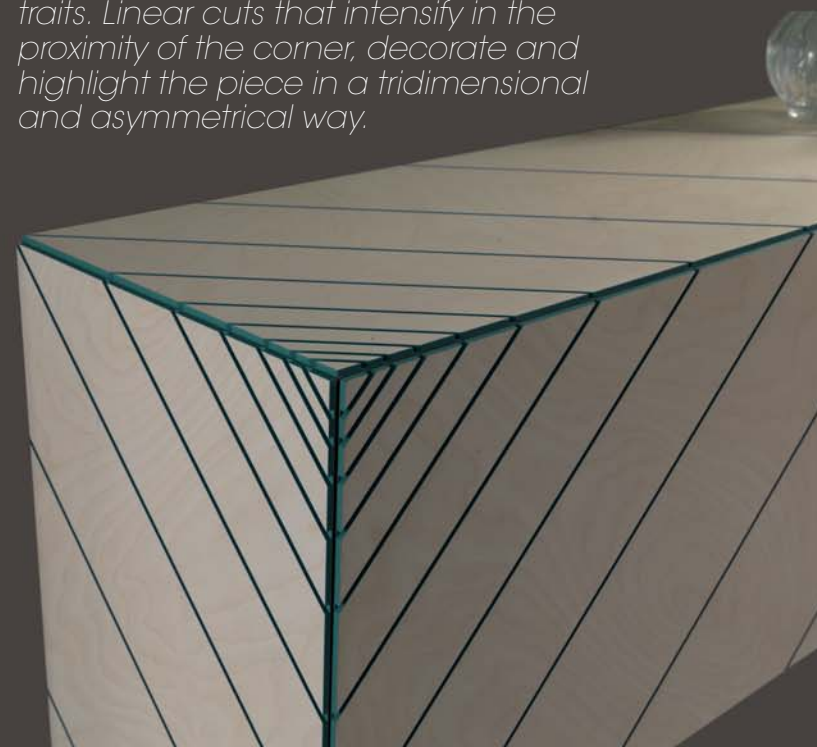

HIVE

design: Bero - Giacomassi - Ferrari

LIBRERIA

Dimensioni:
L 50 x P 22/30/38 x H 43 cm

Materiali:
Legno massello di rovere / cedro;
Struttura in ferro laccata nero

Libreria modulare da parete in legno massello e ferro laccato.



BOOKCASE

Dimensions:
L 50 x W 22/30/38 x H 43

Materials:
Solid oak wood / cedar;
Black lacquered metal structure

Modular wall mounted bookcase
made with solid wood and lacquered
metal.



DURAME®

TAVOLI

TABLES

VUOTO

design: Dmitry Kozinenko



TAVOLO

Dimensioni:
L 120 x H 73,5 cm (base singola)
L 250 x P 100 x H 73,5 cm
(base doppia)

Materiali:
Base: legno massello di rovere /
noce canaletto;
Piano: marmo / cristallo

Il tavolo Vuoto è una combinazione di materiali e spazio che crea una sofisticata struttura tridimensionale. La base asimmetrica in legno massello, ha un aspetto diverso se la si guarda da prospettive distinte. Il tavolo può avere diverse funzioni a seconda dell'utilizzo di una o due basi, dando la possibilità di avere piani di diverse forme e dimensioni. Preziose essenze di legno sono abbinare a marmo e vetro per rendere Vuoto ancora più sofisticato.

TABLE

Dimensions:
L 120 x H 73,5 cm (single base)
L 250 x W 100 x H 73,5 cm
(multiple base)

Materials:
Base: solid oak wood /
Solid walnut wood;
Top: marble / crystal

Vuoto table is a combination of material and space that creates a sophisticated tridimensional structure. The asymmetric base in solid wood looks different from different viewing angles. The table can have different developments depending on the use of one or two bases, giving the possibility to have tops of different shapes and sizes. Precious wood essences are combined with marble and glass in order to make Vuoto even more valuable.









RENAISSANCE

design: Dmitry Kozinenko

TAVOLO

Dimensioni:

L 200 x P 95 x H 74 cm

L 220 x P 95 x H 74 cm

L 260 x P 95 x H 74 cm

Materiali:

Struttura in massello di rovere e piano in rovere;

Struttura in massello di noce canaletto e piano in noce canaletto

Un tavolo ispirato alle architetture delle città storiche europee; nelle sue linee leggere si può riconoscere una reinterpretazione della sagoma dell'arco a tutto sesto, tipico degli edifici e delle cattedrali del Rinascimento.

TABLE

Dimensions:

L 200 x W 95 x H 74 cm

L 220 x W 95 x H 74 cm

L 260 x W 95 x H 74 cm

Materials:

Solid oak wood structure and oak wood top;

Solid walnut wood structure and walnut wood top

A table inspired by historical european architecture; looking at this faint lines, one can recognize a reinterpretation of the shape of a full-centre arch, which characterizes buildings and cathedrals of the Renaissance.







TA.ta wood

design: Michele Barberio - XYZ FACTORY

TAVOLO

Dimensioni:

L 200 x P 80 x H 74 cm

L 220 x P 80 x H 74 cm

L 240 x P 80 x H 74 cm

Materiali:

Struttura in massello di rovere e piano in rovere;

Struttura in massello di noce canaletto e piano in noce canaletto

TA.ta wood è realizzato interamente in legno, il tavolo presenta la particolarità di una tasca che si apre sollevando il coperchio a filo tagliato all'interno del top. Una vaschetta in legno posta al di sotto del piano diventa un comodo contenitore per riporre oggetti di piccole dimensioni: nel caso in cui il tavolo sia destinato all'arredo domestico o ad uno spazio di lavoro, la tasca torna sempre utile ed efficace.



TABLE

Dimensions:

L 200 x W 80 x H 74 cm

L 220 x W 80 x H 74 cm

L 240 x W 80 x H 74 cm

Materials:

Solid oak wood structure and oak wood top;

Solid walnut wood structure and walnut wood top

TA.ta wood is made entirely of wood, the peculiarity of this table is a pocket that can be opened by lifting the lid flush cut into the top. A pan wood placed below the plane becomes a convenient container for storing small objects: in the case in which the table is intended for home and furnishing a work space, the pocket always useful and effective.





ICS

design: Paolo Farano

TAVOLO

Dimensioni:

L 180 x P 80 x H 74 cm
L 200 x P 80 x H 74 cm
L 220 x P 80 x H 74 cm
L 240 x P 80 x H 74 cm

Materiali:

Piano: legno massello di rovere /
castagno / noce canaletto;
Struttura: ferro cerato

Tavolo realizzato in legno massello
con struttura in ferro cerato.

TABLE

Dimensions:

L 180 x W 80 x H 74 cm
L 200 x W 80 x H 74 cm
L 220 x W 80 x H 74 cm
L 240 x W 80 x H 74 cm

Materials:

Top: solid oak wood / chestnut /
walnut;
Waxed metal structure

Table made of solid wood
with waxed metal structure.



TUB

design: Paolo Farano

TAVOLO

Dimensioni:

L 180 x P 80 x H 74 cm

L 200 x P 80 x H 74 cm

L 220 x P 80 x H 74 cm

L 240 x P 80 x H 74 cm

Materiali:

Piano: legno massello di rovere /
castagno / noce canaletto;

Struttura: ferro cerato

Tavolo realizzato in legno massello
con struttura in ferro cerato.



TABLE

Dimensions:

L 180 x W 80 x H 74 cm

L 200 x W 80 x H 74 cm

L 220 x W 80 x H 74 cm

L 240 x W 80 x H 74 cm

Materials:

Top: solid oak wood / chestnut /
walnut;

Waxed metal structure

Table made of solid wood with waxed
metal structure.



DURAME®

TAVOLINI

LOW TABLES

TEA

design: Sara Ferrari



TAVOLINO CONTENITORE

Dimensioni:

Vaso in vetro:

diam. 40 x H 32 cm (Basso);

diam. 40 x H 38 cm (Alto)

Top in legno massello:

diam. 38,5 x H 3,5 cm (Piccolo);

diam. 50 x H 3,5 cm (Grande)

Materiali:

Vaso in vetro, colori: fumé / ambra / rosa / blu;

Top: in legno massello di rovere / rovere tinto nero / rovere tinto grigio / noce canaletto / laccato lucido

Maniglia in cuoio (Top piccolo)

Una serie di tavolini contenitore composti da un grande vaso in vetro colorato in cui riporre oggetti, riviste o altri beni personali e da un "tappo" in legno che funge da piano d'appoggio, utilizzabile anche come vassoio.

CONTAINER SIDE TABLE

Dimensioni:

Glass vase:

diam. 40 x H 32 cm (Low);

diam. 40 x H 38 cm (High)

Solid wood top:

diam. 38,5 x H 3,5 cm (Small);

diam. 50 x H 3,5 cm (Large)

Materials:

Glass vase colors: smoked / amber / pink / blue;

Top: solid oak wood / black stained oak / grey stained oak / walnut / glossy lacquered wood

Leather handle (Small top)

A little series of small container tables made up of a big colorful glass vase in which you can place objects, newspapers or other personal items and a wooden cap that works as a table top and can be useful as a tray.







JEAN

design: Uto Balmoral

TAVOLINO

Dimensioni:

L 57 x P 72 x H 28 cm (Piccolo);
L 57 x P 72 x H 38 cm (Piccolo);
L 160 x P 91 x H 28 cm (Grande);
L 160 x P 91 x H 38 cm (Grande)

Materiali:

Piano: laccato blu / bordeaux / rosa
(altri colori a richiesta);
Gambe: ottone / laccato nero

Tavolini asimmetrici e sovrapponibili, dove dinamismi e linee spezzate ammorbidite da leggeri raggi di curvatura danno la possibilità a questi pezzi di adattarsi alle più svariate situazioni domestiche e non, generando vibrazioni e piacevoli spiazamenti.

Caratterizzato da piani colorati laccati lucido e gambe in ottone o in ferro; Jean risulta essere un oggetto dove forme, materiali e colori diversi convivono insieme.



SIDE TABLE

Dimensioni:

L 57 x W 72 x H 28 cm (Small);
L 57 x W 72 x H 38 cm (Small);
L 160 x W 91 x H 28 cm (Big);
L 160 x W 91 x H 38 cm (Big)

Materiali:

Top: lacquered blue / bordeaux / pink
(other colors on request);
Brass legs / black lacquered legs

Side tables dynamisms and broken lines softened by slight bending radii give the possibility to these pieces to adapt to the most varied domestic and non-domestic situations.

Jean is an object where different shapes, materials and colors coexist together: it's characterized by colored lacquered or wooden tops and legs made of brass or iron.







NAZCA

design: Elena Salmistraro

TAVOLINO

Dimensioni:
L 130 x P 97 x H 35 cm

Materiali:
Legno massello e tranciato di rovere

Un coffee-table dal forte contenuto simbolico, con un piano in legno dalla forma asimmetrica e armoniosa, priva di spigoli, impreziosita da disegni geometrici incisi che traggono ispirazione dai geoglifi del Deserto di Nazca.

SIDE TABLE

Dimensioni:
L 130 x W 97 x H 35 cm

Materiali:
Solid oak and veneer wood

*A coffee-table with a high symbolic content.
Its surface is characterized by a an harmonious and asymmetric shape, without sharp edges.
It is also adorned by carved geometrical motifs, inspired by the geoglyphs of the Nazca Desert.*





KURTZ

design: Vernicemogano

TAVOLINO

Dimensioni:
L 140/145 ca. x P 45 x H 37 cm

Materiali:
Legno massello di cedro sabbato;
Struttura in ferro laccata nero;
Piano in vetro

Una forma geometrica lineare di metallo e vetro cattura una sezione di tronco di legno e si fonde con essa per spartirsi identità e funzionalità.

SIDE TABLE

Dimensions:
L 140/145 ca. x W 45 x H 37 cm

Materials:
Sandblasted solid cedar wood;
Black lacquered metal;
Glass top

A linear geometrical shape made of metal and glass catches a log wood section and blends with it to share their identities and functionalities.



MARLOW

design: Vernicemogano

TAVOLINO

Dimensioni:
L 60 x P 50 x H 50 cm

Materiali:
Legno massello di cedro sabbato
laccato nero;
Struttura in ferro laccata nero;
Piano in vetro

Ad una essenziale struttura di metallo e vetro formalmente incompleta viene in soccorso una sezione di tronco di legno che, innestandosi su di essa, si inventa supporto dalla forte valenza organica.

SIDE TABLE

Dimensions:
L 60 x W 50 x H 50 cm

Materials:
Sandblasted black lacquered solid
cedar wood;
Black lacquered metal;
Glass top

A section of a wood long gives aid to a formally unended structure made by metal and glass, creating a valuable organic frame.



TOC

design: Durame
in collaboration with Paolo Farano

TAVOLINO

Dimensioni:
diam. tra 50 cm e 60 cm ca. / H 26 cm
(Tre gambe);
diam. tra 65 cm e 90 cm ca. / H 26 cm
(Quattro gambe)

Materiali:
Legno massello di cedro sabbaiato;
Struttura in ferro cerato

Tavolino realizzato con sezione
di tronco di legno e gambe in ferro
cerato.



SIDE TABLE

Dimensioni:
diam. 50/60 cm ca. / H 26 cm
(Three legs);
diam. 65/90 cm ca. / H 26 cm
(Four legs)

Materiali:
Sandblasted solid cedar wood;
Waxed metal

Side table made with a log wood
section and waxed metal legs.



InsTABLE

design: Michele Barberio – XYZ FACTORY

TAVOLINO

Dimensioni:
L 90 ca. x P 70 ca. x H 35 cm

Materiali:
Legno massello di cedro sabbato;
Struttura in ferro laccata nero
con piedi in legno massello

Tavolino realizzato con sezioni di tronco
di legno e gambe in ferro verniciato.



COFFEE TABLE

Dimensions:
L 90 ca. x W 70 ca. x H 35 cm

Materials:
Sandblasted solid cedar wood;
Black lacquered metal legs with solid
wood feet

Side table made with a log wood
section and lacquered metal legs.



DURAME®

SEDUTE

SEATINGS

MILLEMIGLIA SUPER

design: Andrea Gerosa

SEDIA

Dimensioni:
L 70 x P 56 x H 63 cm (H seduta 38 cm)

Materiali:
Struttura: legno massello di rovere /
rovere tinto nero / noce canaletto;
Seduta: imbottita in tessuto / pelle

Millemiglia Super è una poltroncina bassa e confortevole, con braccioli, schienale curvato e soffice seduta imbottita. La struttura interamente in legno massello di rovere o noce canaletto, è disponibile in differenti colori e finiture, così come la seduta imbottita che può essere realizzata in diverse varianti.

CHAIR

Dimensions:
L 70 x W 56 x H 63 cm (H seat 38 cm)

Materials:
Structure: solid oak wood / Black stained
solid oak wood / solid walnut wood;
Seat: cloth padding / leather

Millemiglia Super is a low and comfortable armchair with a curved back and a soft padded seat. The structure is made by solid wood (oak or canaletto walnut) and it's available in different colors and finishes. Also the seat is available in different options.







MILLEMIGLIA

design: Andrea Gerosa

SEDIA

Dimensioni:
L 57 x P 50 x H 75 cm (H seduta 45 cm)

Materiali
Mod. Natural: Struttura e seduta in legno massello di rovere / noce canaletto;

Mod. Color: Struttura in massello di rovere / noce canaletto;
Seduta in legno massello verniciato (disponibile in vari colori)

Mod. Light soft: Struttura in massello di rovere / noce canaletto;
Seduta in legno massello e imbottitura in pelle

Mod. Extra soft: Struttura in massello di rovere / noce canaletto;
Seduta completamente imbottita in pelle / tessuto

Ispirata alle affascinanti forme dei bolidi a motore del passato, Millemiglia è una seduta in legno massello con braccioli, dalle forme slanciate ed ergonomiche.

CHAIR

Dimensions:
L 57 x W 50 x H 75 cm (H seat 45 cm)

Materials
Natural option: boat structure and seat in solid oak wood / walnut;

Colored option: solid oak wood structure / walnut;
Varnished solid oak wood seat / walnut (colours on request);

Light soft option: solid oak wood structure / walnut;
Solid wood seat with a part of leather padding;

Extra soft option: solid oak wood structure / walnut;
Seat leather or cloth padding

The fascinating shapes of the old racing cars inspired Millemiglia, a thin and ergonomic chair with armrests and made of solid wood.





CROSS

Archivio Storico Moltenimobili/Durame
+ Uto Balmoral

SEDIA

Dimensioni:
L 40 x P 40 x H 77 (H seduta 44 cm)

Materiali:
Struttura in legno massello di rovere /
rovere tinto nero / noce canaletto;
Seduta in cinghie di tessuto tecnico
intrecciate disponibili in vari colori

Dall'Archivio Storico
Moltenimobili/Durame, ecco una
famiglia di sedute dove leggerezza
e versatilità caratterizzano una struttura
in legno massello e tessuto tecnico.



CHAIR

Dimensions:
L 40 x W 40 x H 77 (H seat 44 cm)

Materials:
Solid oak wood / Black stained solid oak
wood / Solid walnut wood;
Seat made of technical woven
intersected belts available in different
colours

From Moltenimobili/Durame's Historical
Archive, a family of seats whose lightness
and versatility characterize a structure
made of solid Wood and technical
woven.

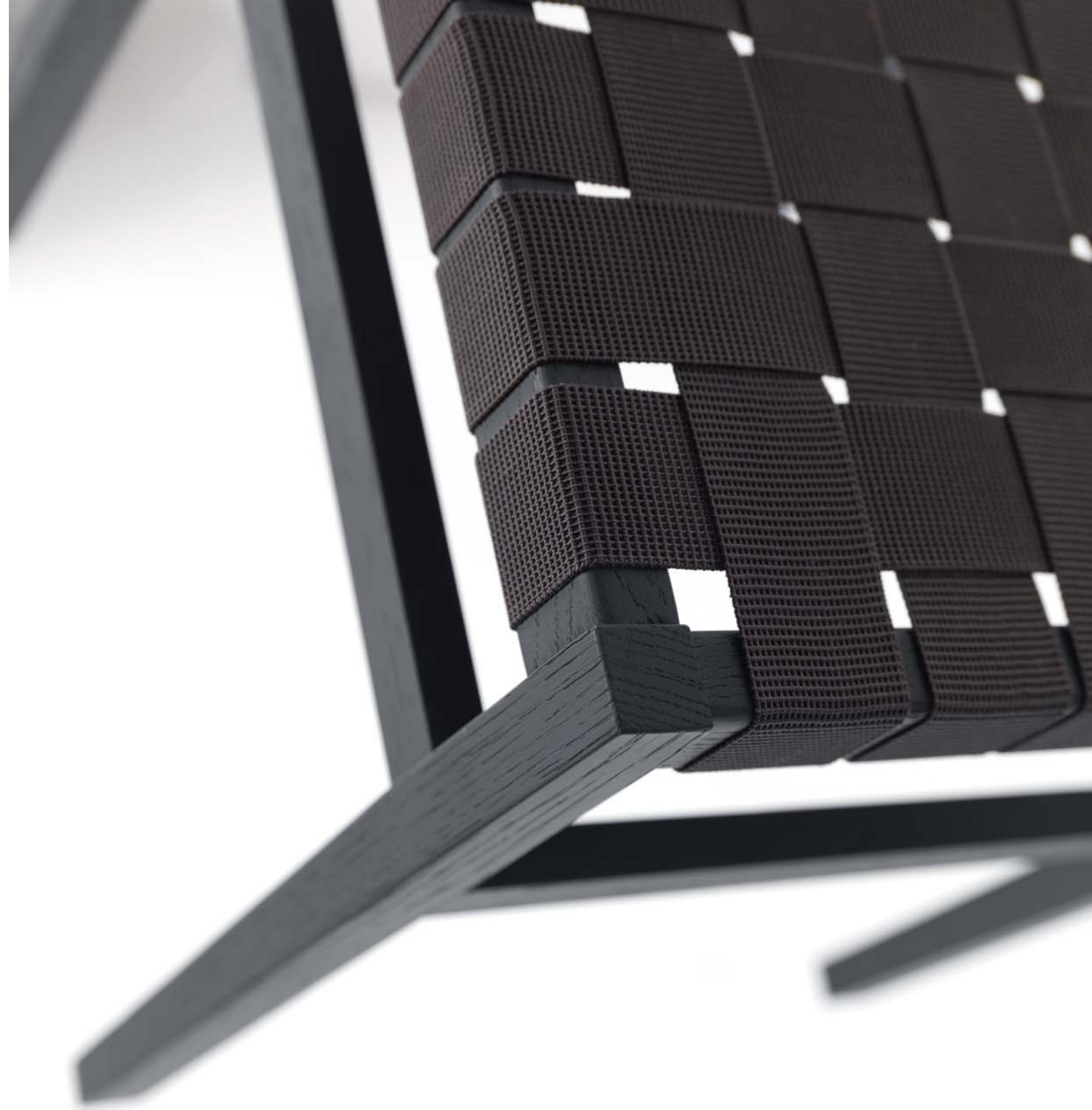



CROSS

Archivio Storico Moltenimobili/Durame
+ Uto Balmoral



POLTRONCINA / POGGIPIEDI

Dimensioni:

Poltroncina piccola:

L 55 x P 55 x H 77 (H seduta 40 cm)

Poltroncina grande:

L 65 x P 55 x H 77 (H seduta 40 cm)

Poggiapiedi piccolo: L 45 x P 45 x H 26

Poggiapiedi grande: L 50 x P 45 x H 26

Materiali:

Struttura in legno massello di rovere /
rovere tinto nero / noce canaletto;

Seduta in cinghie di tessuto tecnico
intrecciate disponibili in vari colori;

Cuscino imbottito disponibile in vari
tessuti e colori

Dall'Archivio Storico

Moltenimobili/Durame, ecco una
famiglia di sedute dove leggerezza
e versatilità caratterizzano una struttura
in legno massello e tessuto tecnico.

ARMCHAIR / FOOTREST

Dimensioni:

Small armchair:

L 55 x W 55 x H 77 (H seat 40 cm)

Large armchair:

L 65 x W 55 x H 77 (H seat 40 cm)

Small footrest: L 45 x W 45 x H 26

Large footrest: L 50 x W 45 x H 26

Materials:

Solid oak wood / Black stained solid oak
wood / Solid walnut wood;

Seat made of technical woven
intersected belts available in different
colours;

Plumped cushion available in different
fabrics and colours

From Moltenimobili/Durame's Historical
Archive, a family of seats whose lightness
and versatility characterize a structure
made of solid Wood and technical
woven.





EXPERIMENTA

design: Un Pizzo with Carlo Marelli

POLTRONA

Dimensioni:
L 120 x P 83 x H 82 cm
(H seduta 40 cm)

Materiali:
Struttura in legno massello di rovere /
noce canaletto;
Seduta in cotone 100%;
Cuscino imbottito in tessuto

Una poltrona nata da una ricerca
che unisce due arti tipiche brianzole:
la lavorazione artigianale del legno
e quella del pizzo al tombolo.

ARMCHAIR

Dimensions:
L 120 x P 83 x H 82 cm
(H seat 40 cm)

Materials:
Solid oak wood structure/ solid walnut
structure;
100% cotton seat;
Fabric cushion

An armchair derived from a research
that unifies two traditional arts from
Brianza: wooden handcraft and
bobbin lace.





GRAFT

design: Damien Gernay

SEDIA

Dimensioni:
L 55 x P 45 x H 75 cm
(H seduta 45 cm)

Materiali:
Legno massello di cedro;
Ferro laccato nero

Un semplice tronco di legno tagliato può essere usato come seduta; l'innesto di uno schienale ne aumenta la funzionalità, ne arricchisce l'estetica e lo trasforma in un vero e proprio oggetto d'arredo.



CHAIR

Dimensions:
L 55 x W 45 x H 75 cm
(H seat 45 cm)

Materials:
Solid cedar wood;
Black lacquered metal

*A simple log can be cut and used as a seat; the insertion of a seatback increases its functionality and enriches its aesthetics.
The final result is a real piece of furniture.*





SEMUC

design: Maurizio Di Lauro

SGABELLO

Dimensioni:
diam. 30 x H 30 cm (Piccolo);
diam. 44 x H 41 cm (Grande)

Materiali:
Legno massello di cedro

Semuc è un luogo incantato che ha ispirato uno sgabello che si può utilizzare in modo tradizionale oppure tramutare in una ludica seduta a dondolo. E' adatto sia per spazi interni che esterni.



STOOL

Dimensions:
diam. 30 x H 30 cm (Small);
diam. 44 x H 41 cm (Large)

Materials:
Solid cedar wood

Semuc is an enchanted place that inspired a stool which can be used in the traditional way, but it may even become a recreational rocking chair. Suitable for both outdoor and indoor areas.





DURAME®

COMPLEMENTI

COMPLEMENTS

b2b

design: Vernicemogano

PANCA/PORTARIVISTE-LIBRI

Dimensioni:
L 175 x P 28 x H 38 cm
L 220 x P 28 x H 38 cm

Materiali:
Legno massello di rovere;
Ferro laccato nero

Sedere su una trave, sfogliare un libro,
immaginare



BENCH/MAGAZINE-BOOK RACK

Dimensions:
L 175x W 28x H 38 cm
L 220 x W 28x H 38 cm

Materials:
Solid oak wood;
Black lacquered metal

Sitting on a beam, leafing through
a book, imagine



SEED

design: Uto Balmoral

APPENDIABITI

Dimensioni:
h 185 cm

Materiali:
Legno massello di rovere /
Struttura in ferro verniciata nero;
Legno massello di noce canaletto /
Struttura in ferro ottonato

La terra da frutti solo se viene adeguatamente seminata e nutrita, l'appendiabiti si ispira all'immagine poetica dei primi germogli che appaiono ed escono dal terreno nella fase di crescita, immediatamente precedente la fioritura.



COAT HANGER

Dimensioni:
h 185 cm

Materiali:
Solid oak wood / Lacquered metal;
Solid walnut wood / Brass metal

The earth creates product only if you put seeds in it, the coat hanger is inspired by the poetic image of the sprout in the growing phase just before the blossom.



EDES

design: Paolo Salvadè

SPECCHIO

Dimensioni:
70 x 61 cm (Piccolo);
70 x 115 cm (Grande)

Materiali:
Legno massello rovere /
noce canaletto;
Specchio

Uno specchio dalle linee semplici,
con una cornice sfaccettata in legno
massello, impreziosita da un'elegante
asimmetria.

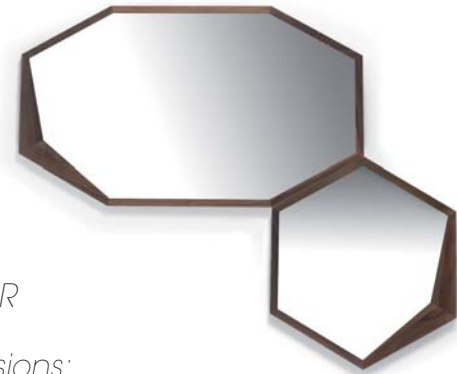

MIRROR

Dimensions:
70 x 61 cm (Small);
70 x 115 cm (Large)

Materials:
Solid oak wood / walnut;
Mirror glass

A simple-shaped mirror with
a multifaceted frame made of solid
wood, and decorated with an elegant
asymmetry.



ETNA

design: studio BAAG

SPECCHIERA

Dimensioni:

Specchio ellittico 55x H 77 cm

Specchio circolare diam. 60 cm

Materiali:

Legno massello di noce canaletto /

Legno laccato bronzo anticato;

Specchio

Linee morbide in legno massello definiscono una sagoma organica e naturale. Superfici concave e convesse che si inseguono, si compenetrano fino a fondersi in un cratere in cui riflettere la propria immagine per lasciarsene catturare l'essenza.



MIRROR

Dimensions:

Elliptical mirror 55x77 cm

Circular mirror diam. 60 cm

Materials:

Solid walnut wood /

Antiqued bronze lacquered wood;

Mirror glass

Soft lines in solid wood define an organic and natural silhouette. Concave and convex surfaces chase and penetrate each other until merging into a crater, in which to reflect the image of yourself and to capture your essence.



DURAME®

ACCESSORI

ACCESSORIES

AMO

design: Maurizio Di Lauro

GANCIO APPENDIABILI

Dimensioni:

L 10 x H 12,5 cm (Piccolo);

L 11 x H 14 cm (Medio);

L 14 x H 17,5 cm (Grande)

Materiali:

Legno massello di rovere / noce

canaletto / ciliegio / acero /

multistrato di betulla;

Cavo in acciaio

Un leggero manufatto in legno che si staglia sospeso nello spazio rivelandosi una presenza discreta dalla forte valenza evocativa. Si compone di un sottile cavo d'acciaio e una sorta di amo a cui appendere indifferentemente abiti, cappelli, borse...



COAT HANGER

Dimensioni:

H 12,5 cm (Small);

H 14 cm (Medium);

H 17,5 cm (Large)

Materiali:

Solid oak wood / walnut / cherry /

maple / birch plywood;

Steel cable

A light artefact that seems to hover in the space.

It defines a discreet presence

with a strong evocative value.

It consists of a thin steel cable and a sort of hook to which either hanging clothes, hats, bags...



JOINT

design: Uto Balmoral

PORTAFRUTTA

Dimensioni:
28,5 x 28,5 cm

Materiali:
Legno massello di rovere / noce
canaletto / ciliegio / acero

Portafrutta costituito da due forme
che si compenetrano. L'unione
fra di esse genera un unico elemento.
Può essere utilizzato sia singolarmente
che separatamente.



FRUIT BOWL

Dimensioni:
28,5 x 28,5 cm

Materiali:
Solid oak wood / walnut / cherry /
maple

Fruit bowl generated by a connection
between two wooden sliced shapes.
The junction create a single bowl
which can be doubled if necessary.



QUATTROQUARTI

design: Uto Balmoral

PORTAFRUTTA

Dimensioni:
32 x 32 cm

Materiali:
Legno massello di rovere /
noce canaletto / ciliegio / acero

Un portafrutta che dà l'idea
di essere stato tagliato e riassembleto
maldestramente.

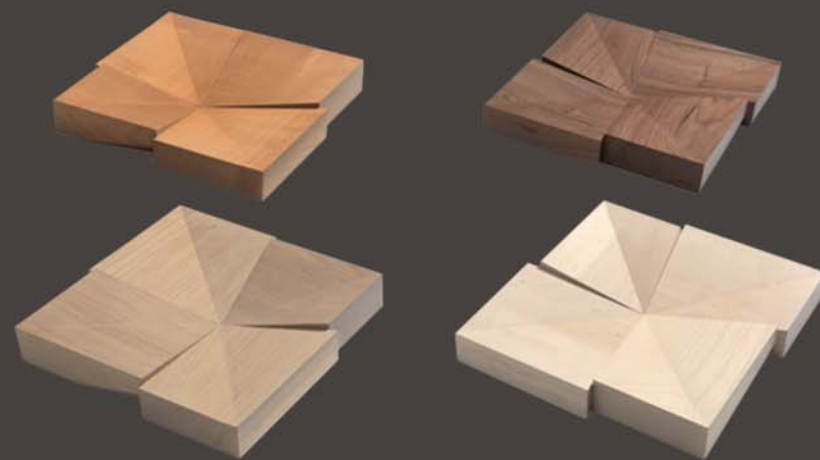

FRUIT BOWL

Dimensioni:
32 x 32 cm

Materiali:
Solid oak wood / walnut
cherry / maple

A fruit bowl that looks like
it has been cut and randomly
re-assembled.

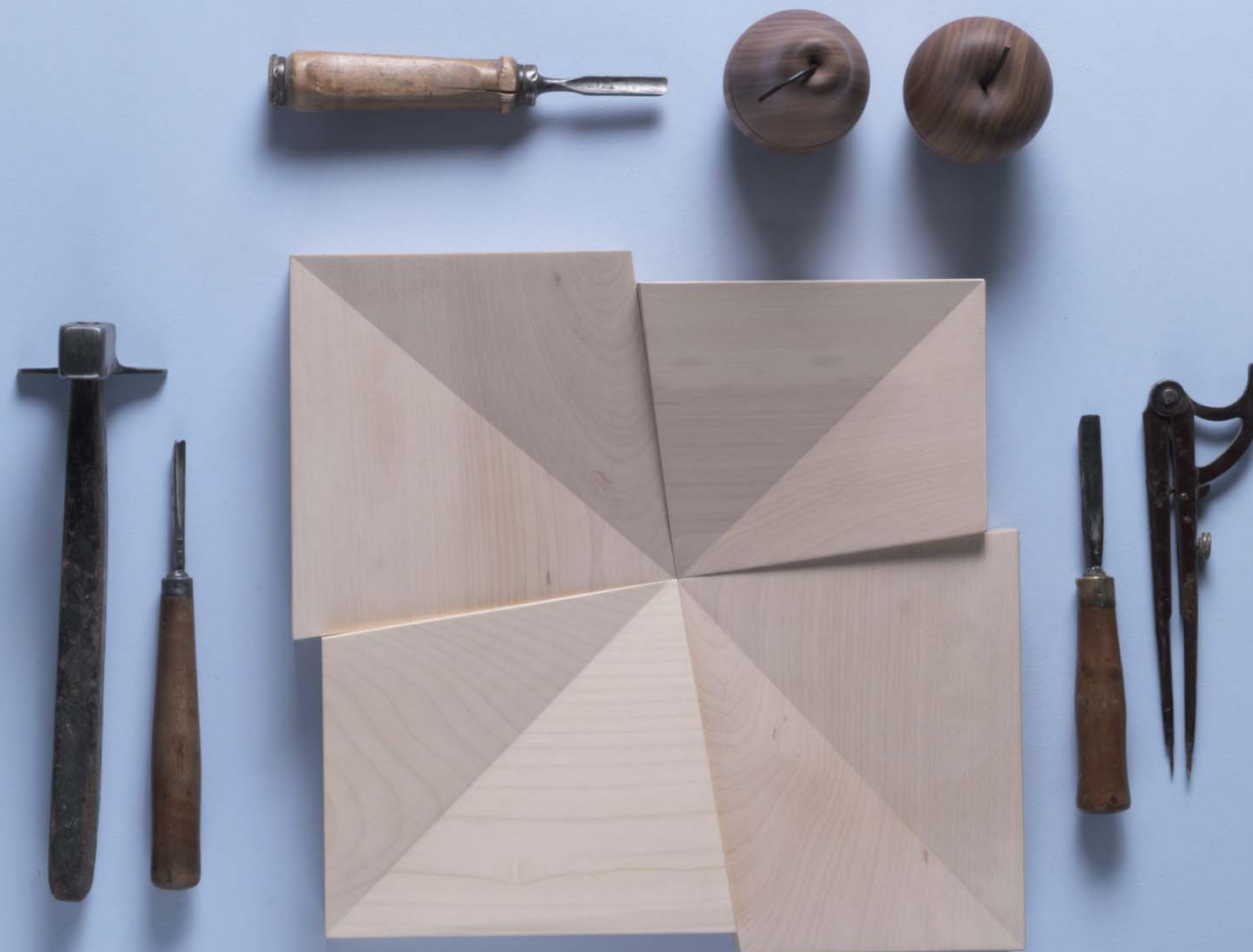

NORMANN

design: Antonio Norero

PORTAFOTO/SEGNAPOSTO

Dimensioni:
H 10 cm

Materiali:
Legno massello di rovere /
noce canaletto;
Magnet

Un piccolo oggetto di legno dotato di calamita, pensato per reggere foto, biglietti da visita, documenti o per evidenziare un invito.

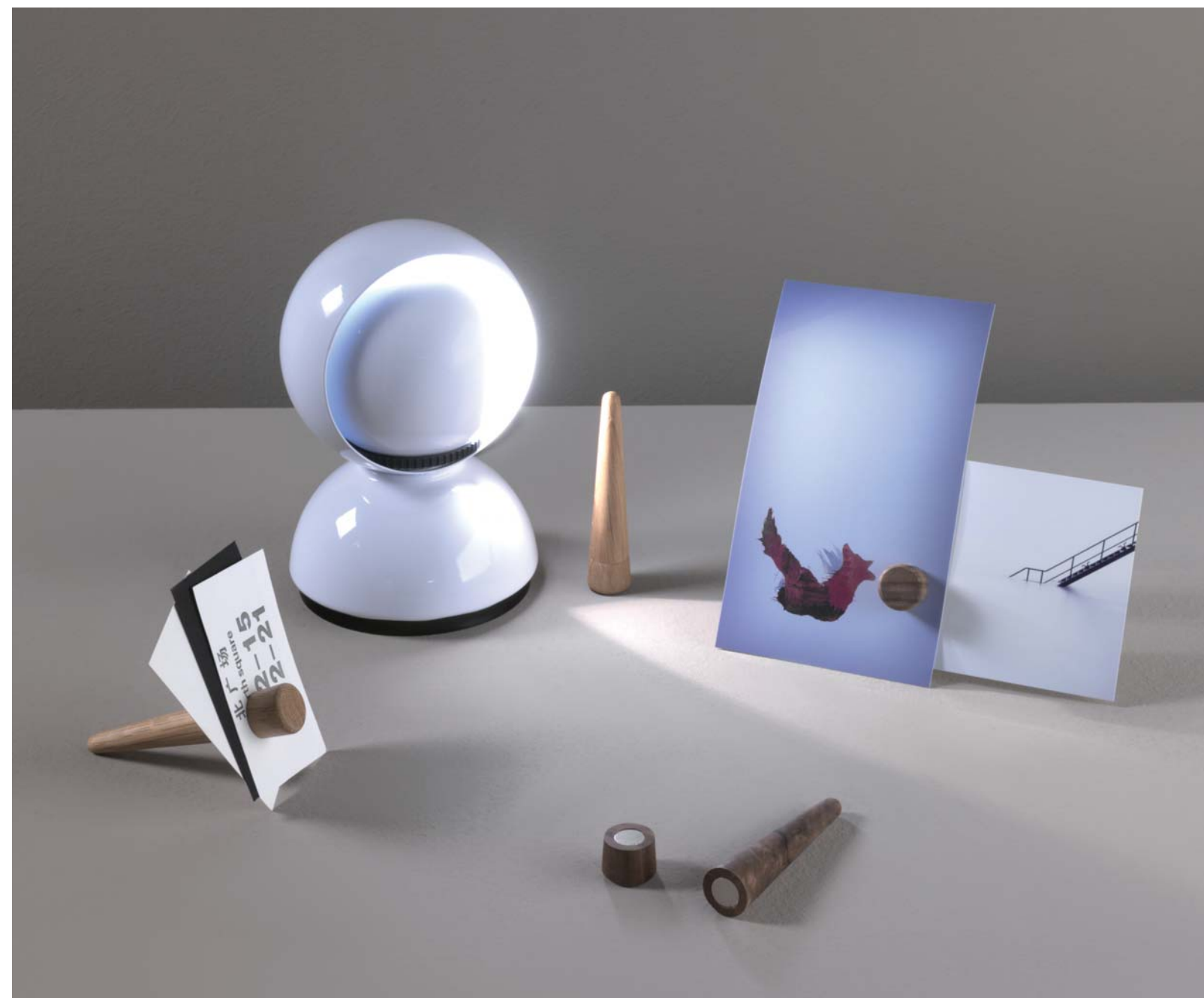

PHOTO HOLDER/PLACEHOLDER

Dimensions:
H 10 cm

Materials:
Solid oak wood / walnut;
Magnet

A small wooden object with magnet, designed to display photos, business cards, documents or to highlight an invitation.



QUBO

design: Durame

SCATOLA

Dimensioni:
L 12 x P 12 x H 13 cm

Materiali:
Legno massello di rovere /
noce canaletto / ciliegio / palissandro

Scatola cubica in legno massello
realizzato in varie essenze.



BOX

Dimensions:
L 12 x W 12 x H 13 cm

Materials:
Solid oak wood / walnut / cherry /
rosewood

Cubic box made of solid wood
in various essences.



SUSHI

design: Durame

VASSOIO

Dimensioni:
28 x 28 cm (Piccolo)
38 x 28 cm (Grande)

Materiali:
Legno massello di rovere /
noce canaletto / ciliegio / acero

Vassoio in legno massello.



TRAY

Dimensions:
28 x 28 cm (Small)
38 x 28 cm (Large)

Materials:
Solid oak wood /
walnut / cherry / maple

Tray made of solid wood.



STELO

design: Durame

VASO

Dimensioni:
diam. 7 x H 17 cm (Piccolo)
diam. 7 x H 24 cm (Grande)

Materiali:
Legno massello di rovere /
noce canaletto / ciliegio / acero /
wengé

Vaso in legno massello.



VASE

Dimensioni:
diam. 7 x H 17 cm (Small)
diam. 7 x H 24 cm (Large)

Materiali:
Solid oak wood / walnut / cherry /
maple / wengé

Vase made of solid wood.



MELA/PERA

design: Durame

CONTENITORI

Dimensioni:

Mela H 7 cm / Pera H 11 cm
(Piccola)

Mela H 9 cm / Pera H 15 cm
(Grande)

Materiali:

Legno massello di rovere /
noce canaletto / ciliegio / acero

Contenitori realizzati in legno massello.



HOLDERS

Dimensioni:

Mela H 7 cm / Pera H 11 cm
(Small)

Mela H 9 cm / Pera H 15 cm
(Large)

Materiali:

Solid oak wood / walnut / cherry /
maple

Holder made of solid wood.



LUME

design: Durame



PORTALUME

Dimensioni:
H 5 cm (Piccolo) / H 7 cm (Medio)
H 9 cm (Grande)
diam. 8 cm (Sferico piccolo)
diam. 9 cm (Sferico grande)

Materiali:
Legno massello di rovere /
noce canaletto / ciliegio /
acero / wengé / teak

Portalume in legno massello.

CANDLE HOLDER

Dimensions:
H 5 cm (Small) / H 7 cm (Medium)
H 9 cm (Large)
diam. 8 cm (Spherical small)
diam. 9 cm (Spherical large)

Materials:
Solid oak wood / walnut /
cherry / maple / wengé / teak

Candle holder made of solid wood.



ASET

design: Durame

TAGLIERE

Dimensioni:
diam. tra 20 cm e 30 cm ca.

Materiali:
Legno massello di rovere / castagno /
ulivo / cedro / robinia / pino

Tagliere in legno massello.



CHOPPING BOARD

Dimensions:
diam. 20/30 cm ca.

Materials:
Solid oak wood / chestnut / wild olive /
cedar / black locust / pine

Chopping board made of solid wood.



BOCCIA

design: Durame

PORTABOTTIGLIE

Dimensioni:
diam. 21 cm

Materiali:
Legno massello di rovere /
noce canaletto / ciliegio

Porta bottiglia in legno massello.

BOTTLE RACK

Dimensions:
diam. 21 cm

Materials:
Solid oak wood/
walnut / cherry

Bottle rack made of solid wood.



DURAME®

DATI TECNICI

TECHNICAL DATA

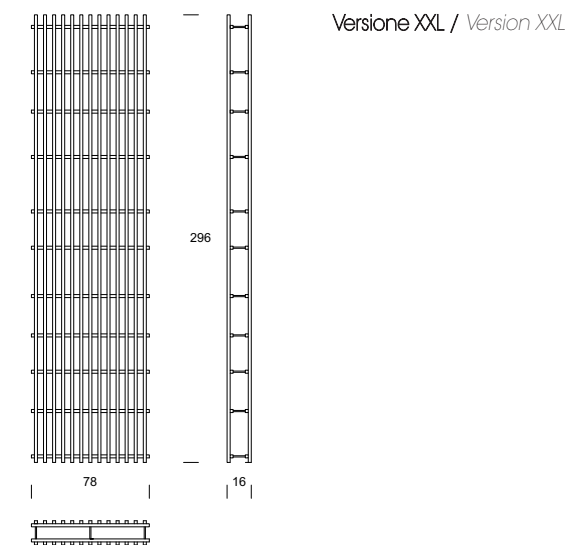
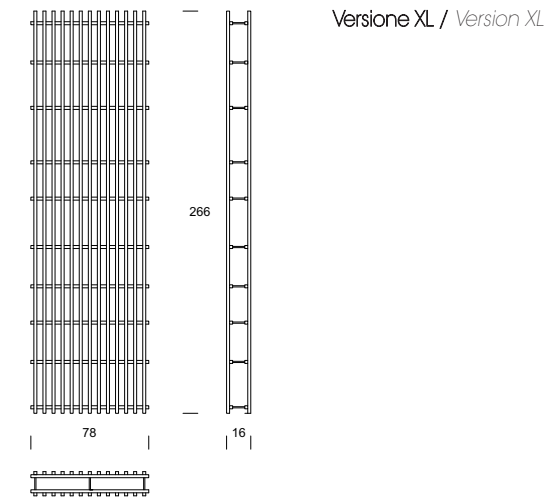
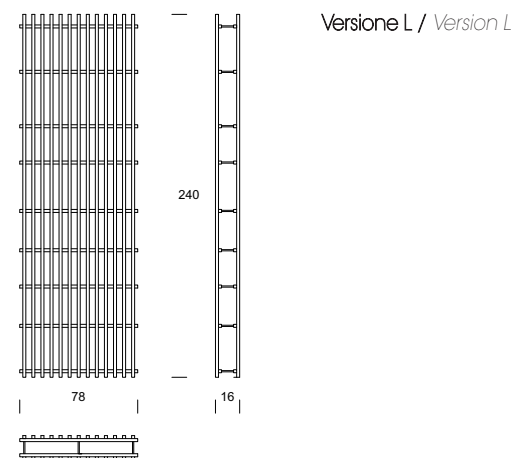
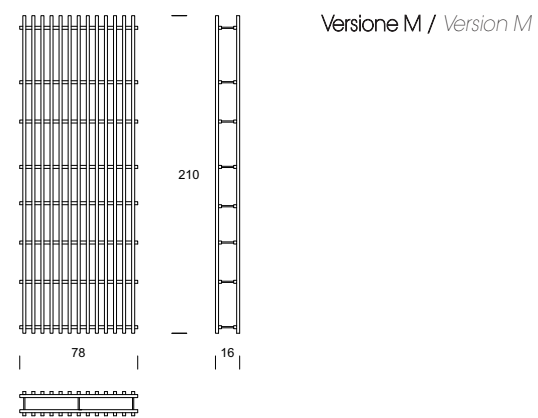
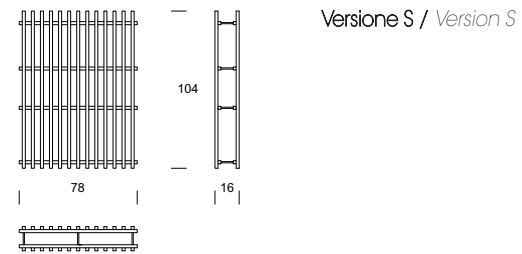

DATI TECNICI | TECHNICAL DATA

CRAB MOBILE CONTENITORE / CABINET

P. 16 - 21

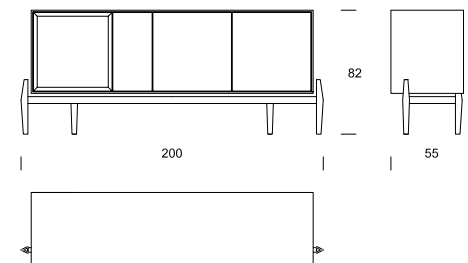
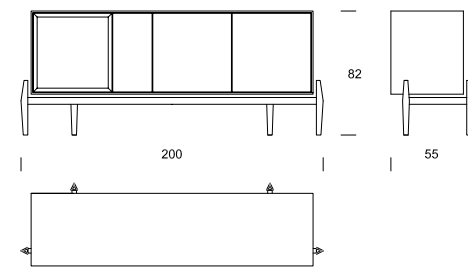
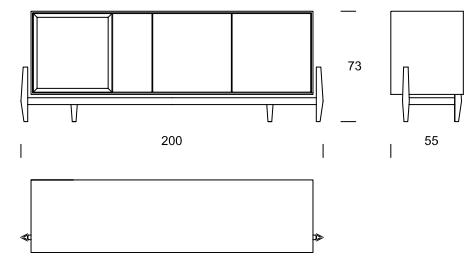
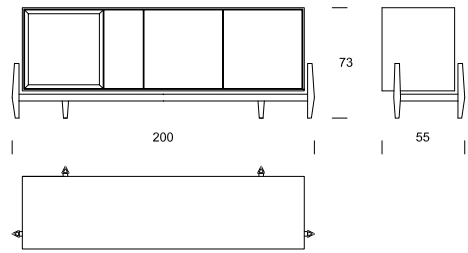

CRAB MOBILE CONTENITORE / CABINET

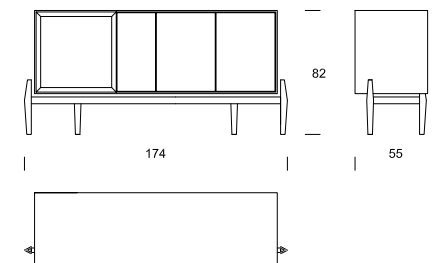
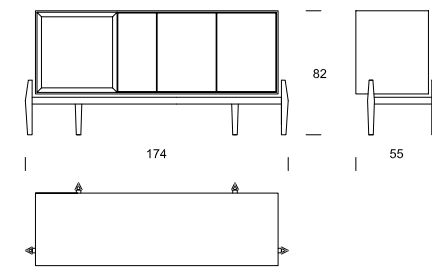
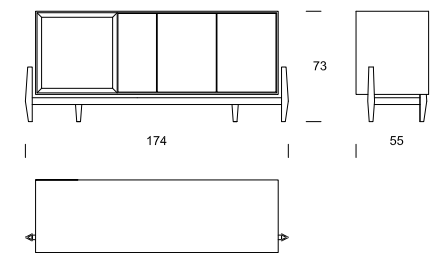
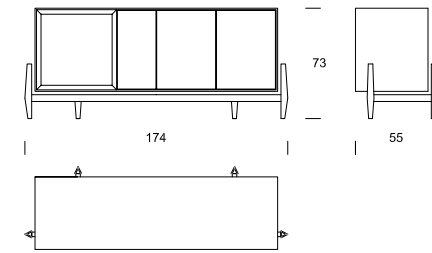

DATI TECNICI | TECHNICAL DATA

CRAB MOBILE CONTENITORE ALTO / HIGH CABINET

P. 22 - 25

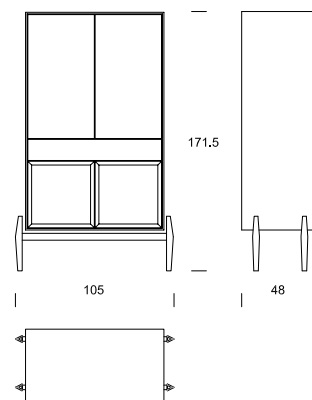
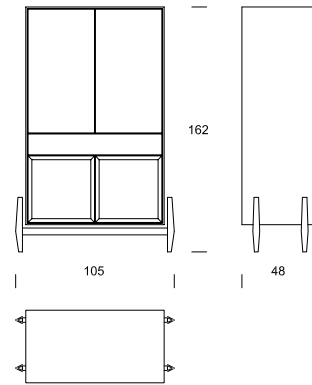

BREATHE MOBILE CONTENITORE / CABINET

P. 26 - 31

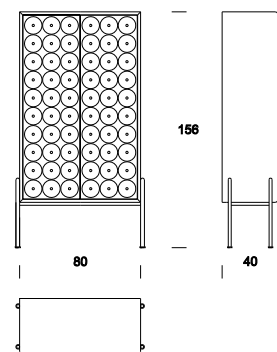

LIPSTICK MOBILE CONTENITORE / CABINET

P. 32 - 37

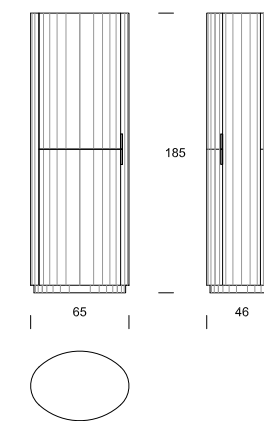

Versione TOTAL COLOR
Version TOTAL COLOR

Versione COLOR+WOOD
Version COLOR+WOOD

ELLA MADIA / SIDEBBOARD

P. 38 - 41

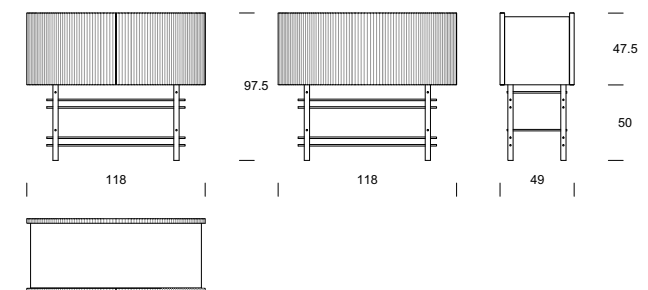
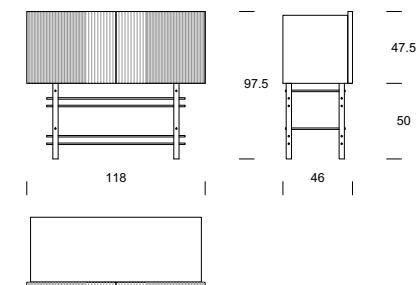

Versione BIFACCIALE / Version BIFACIAL

Vassoio in legno estraibile a richiesta / Pull-out wood tray on request

DATI TECNICI | TECHNICAL DATA

SIPARIO MOBILI CONTENITORI / CABINETS

P. 42 - 45

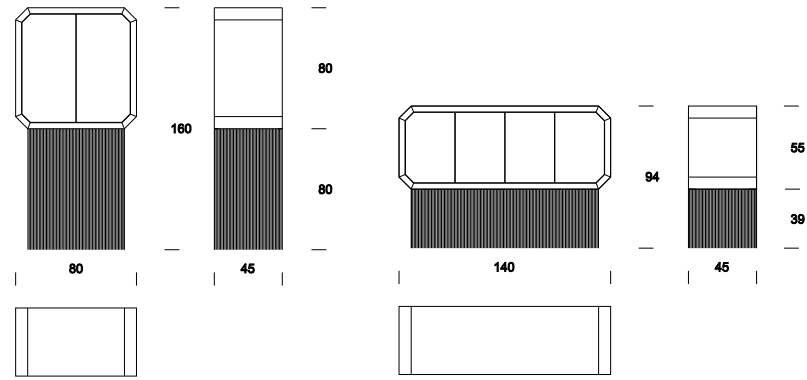

GROW LIBRERIA / BOOKCASE

P. 46 - 49

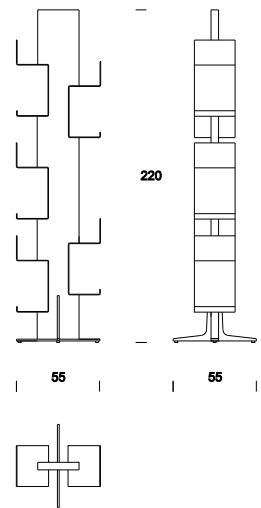

CAMINETTO MOBILI CONTENITORE / CABINET

P. 50 - 51

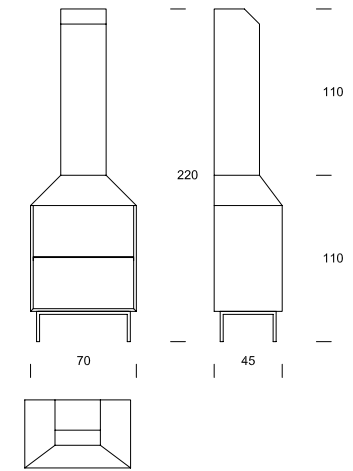

ASTEROID LIBRERIA / BOOKCASE

P. 52 - 55

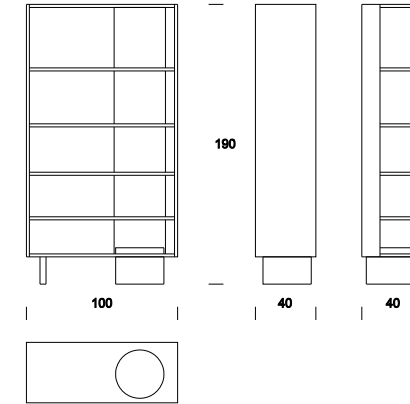

DATI TECNICI | TECHNICAL DATA

4x4Wood MOBILE CONTENITORE / CUPBOARD

P. 56-59

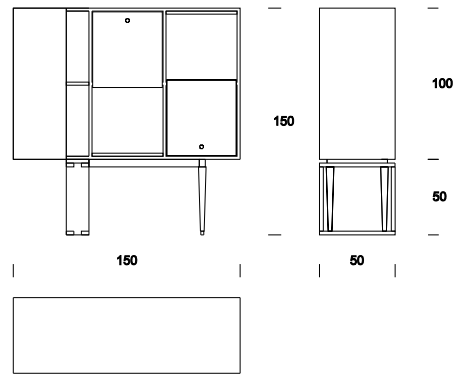

THE EDGE PENSILE CONTENITORE / STORAGE UNIT

P. 60-61

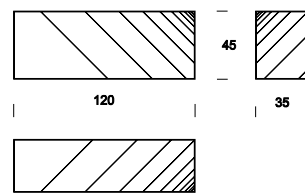

HIVE LIBRERIA / BOOKCASE

P. 62-63

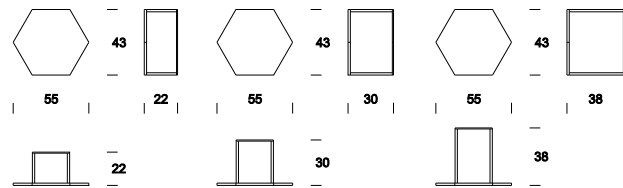

VUOTO TAVOLO / TABLE

P. 66-73

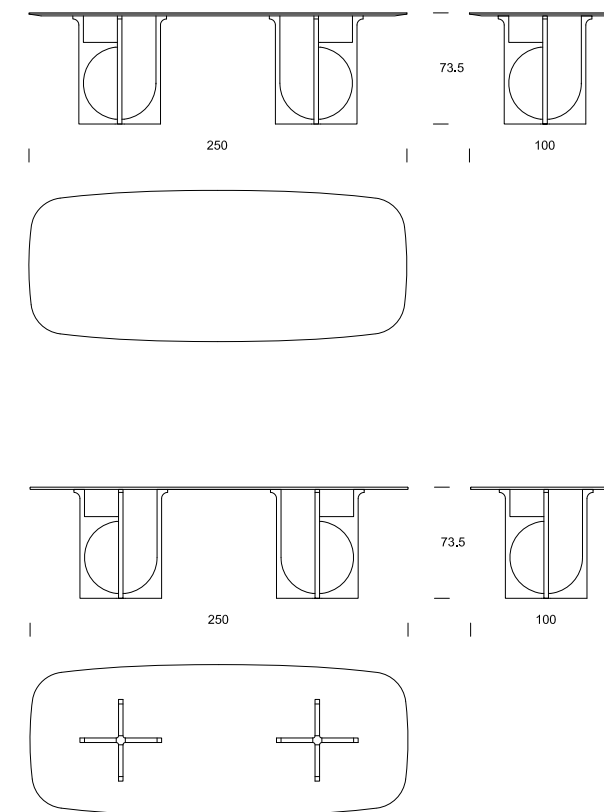

DATI TECNICI | TECHNICAL DATA

VUOTO TAVOLO / TABLE

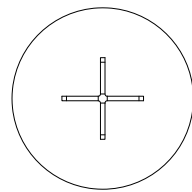
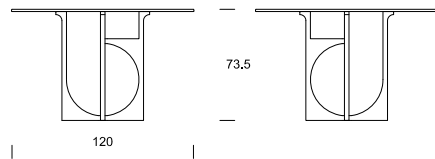
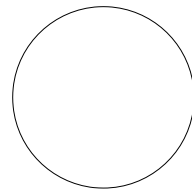
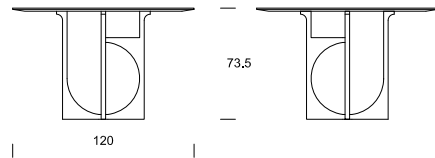

VUOTO TAVOLO / TABLE

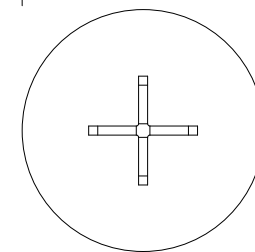
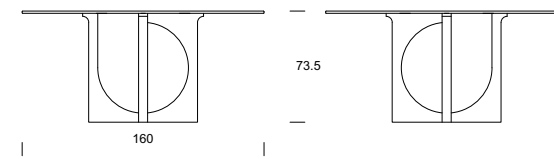
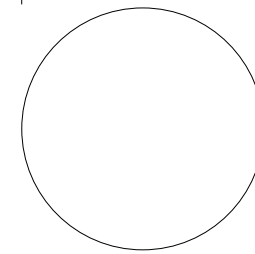
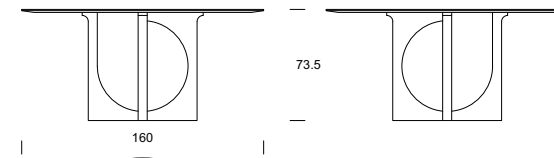

RENAISSANCE TAVOLO / TABLE

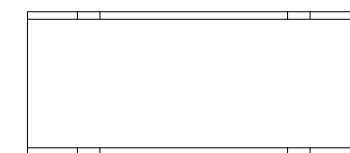
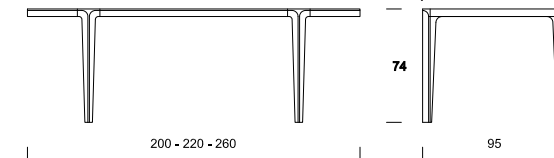

P. 74 - 79

DATI TECNICI | TECHNICAL DATA

TA.ta wood TAVOLO/TABLE

P. 80 - 83

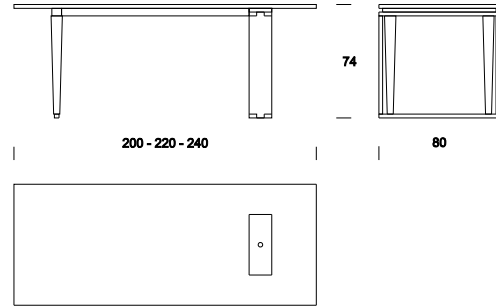

ICS TAVOLO/TABLE

P. 84 - 85

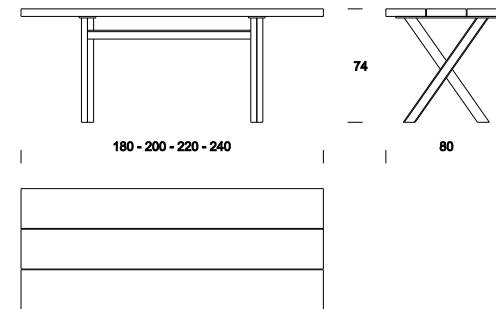

TUB TAVOLO/TABLE

P. 86 - 87

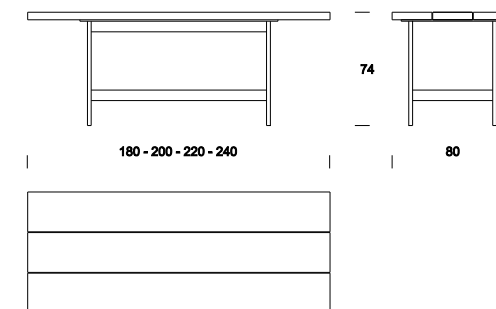

TEA TAVOLINO CONTENITORE/CONTAINER SIDE TABLE

P. 90 - 95

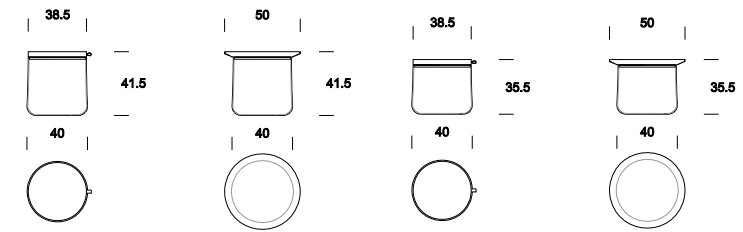

JEAN TAVOLINO/SIDE TABLE

P. 96 - 101

Versione gambe in ottone / Brass legs version

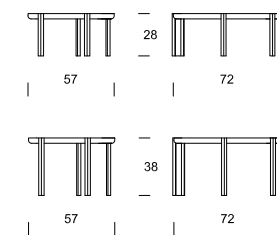

JEAN versione gambe in ferro laccato nero / JEAN legs version in black lacquered iron

Versione gambe in ottone / Brass legs version

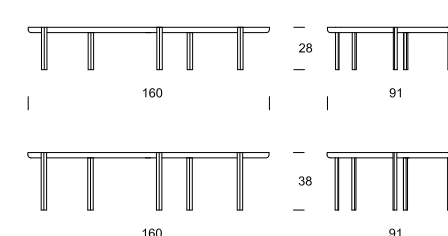

JEAN versione gambe in ferro laccato nero / JEAN legs version in black lacquered iron

DATI TECNICI | TECHNICAL DATA

NAZCA TAVOLO BASSO / LOW TABLE

P. 102 - 105

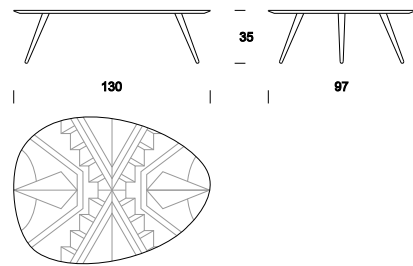

KURTZ TAVOLINO / SIDE TABLE

P. 106 - 107

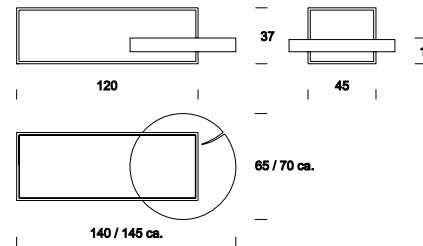

MARLOW TAVOLINO / SIDE TABLE

P. 108 - 109

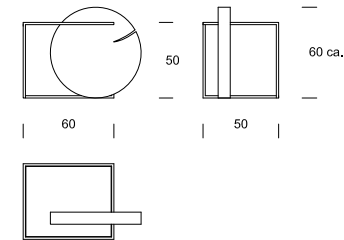

TOC TAVOLINO / SIDE TABLE

P. 110 - 111

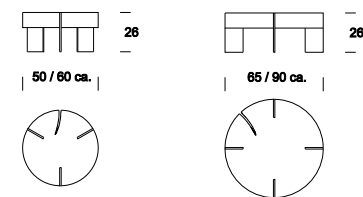

InstTABLE TAVOLINO / COFFEE TABLE

P. 112 - 113

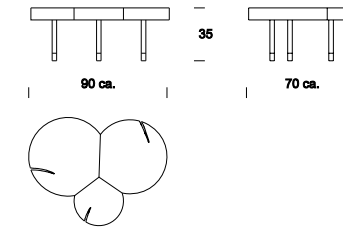

MILLEMIGLIA SUPER POLTRONA / ARMCHAIR

P. 116 - 121

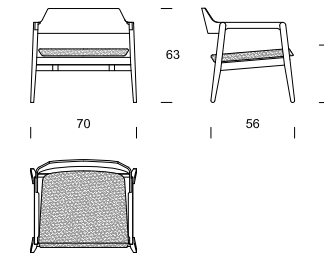

MILLEMIGLIA SEDIA / CHAIR

P. 122 - 125

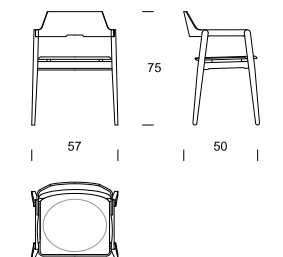

DATI TECNICI | TECHNICAL DATA

CROSS SEDIA/CHAIR

P. 126 - 129

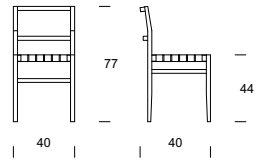

CROSS POLTRONCINA/ARMCHAIR

P. 130 - 133

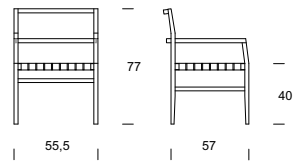

Versione MEDIUM / Version MEDIUM

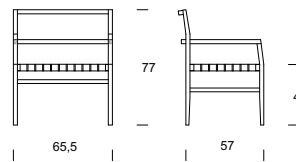

Versione LARGE / Version LARGE



CROSS POGGIAPIEDI/FOOTREST

P. 130 - 133

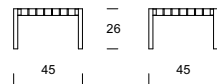

Versione SMALL / Version SMALL

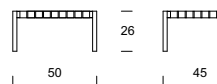

Versione LARGE / Version LARGE



Cuscino imbottito / Plumped cushion

EXPERIMENTA POLTRONA/ARMCHAIR

P. 134 - 137

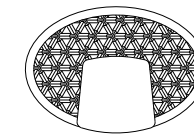
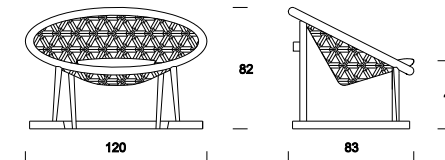

GRAFT SEDIA/CHAIR

P. 138 - 141

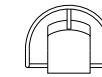
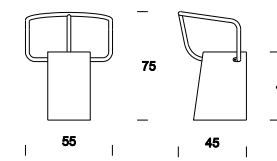

SEMUC SGABELLO/STOOL

P. 142 - 145

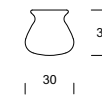

Versione SMALL / Version SMALL

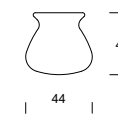

Versione LARGE / Version LARGE



DATI TECNICI | TECHNICAL DATA

b2b PANCA/PORTARIVISTE-LIBRI/BENCH/MAGAZINE-BOOK RACK

P. 148 - 149

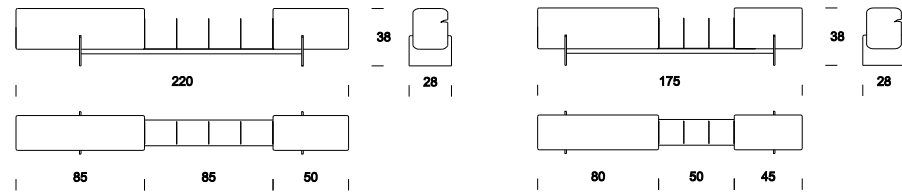

SEED APPENDIABILI/COAT HANGER

P. 150 - 151

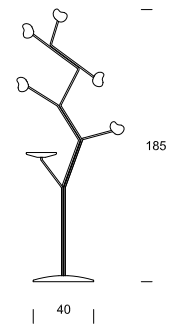

EDES SPECCHIO/MIRROR

P. 152 - 153

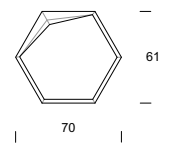

Versione SMALL / Version SMALL

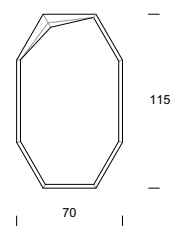

Versione LARGE / Version LARGE

ETNA SPECCHI/MIRRORS

P. 154 - 155

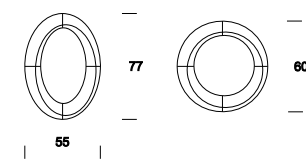

AMO GANCIO APPENDIABILI/COAT HANGER

P. 158 - 159

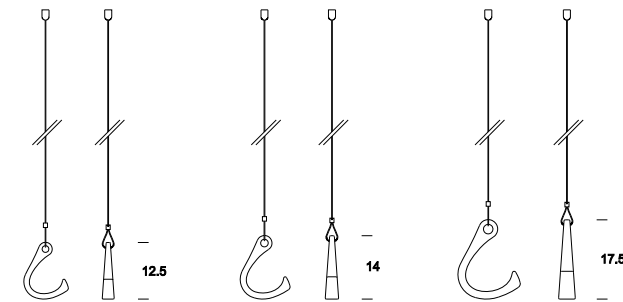

JOINT PORTAFRUTTA/FRUIT BOWL

P. 160 - 161

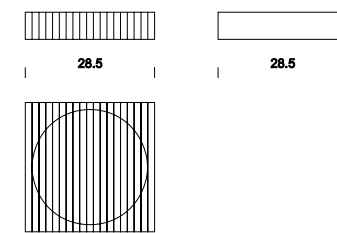

QUATTROQUARTI PORTAFRUTTA/FRUIT BOWL

P. 162 - 163

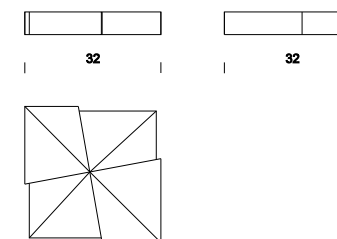

DATI TECNICI | TECHNICAL DATA

NORMANN PORTAFOTO/SEGNAPOSTO/PHOTO HOLDER/PLACEHOLDER P. 164 - 165

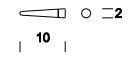

QUBO SCATOLA/BOX P. 166 - 167

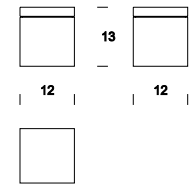

SUSHI VASSOIO/TRAY P. 168 - 169

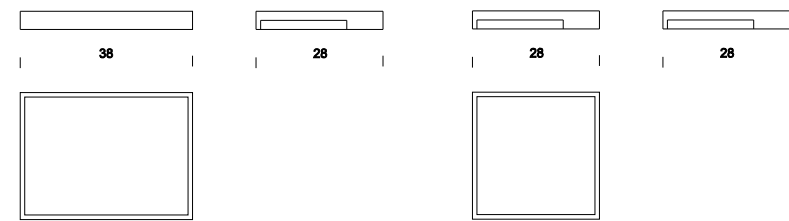

STELO VASO/VASE P. 170 - 171

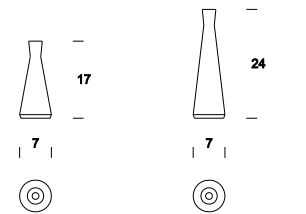

MELA/PERA CONTENITORI/HOLDERS P. 172 - 173

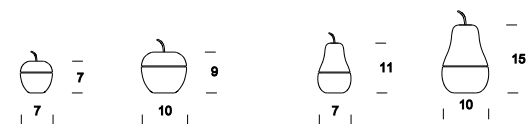

LUME PORTALUME/CANDLE HOLDER P. 174 - 175

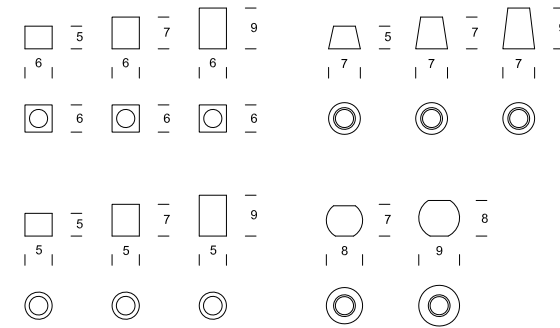

ASÈT TAGLIERE/CHOPPING BOARD P. 176 - 177

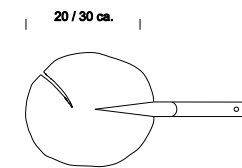

BOCCIA PORTABOTTIGLIE/BOTTLE RACK P. 178 - 179

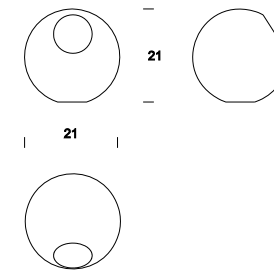

INDICE INDEX

8 - 63 CONTENITORI STORAGE UNITS

SINGOLO	10 - 15
CRAB	16 - 21
CRAB ALTO	22 - 25
BREATHE	26 - 31
LIPSTICK	32 - 37
ELLA	38 - 41
SIPARIO	42 - 45
GROW	46 - 49
CAMINETTO	50 - 51
ASTEROID	52 - 55
4x4Wood	56 - 59
THE EDGE	60 - 61
HIVE	62 - 63

64 - 87 TAVOLI TABLES

VUOTO	66 - 73
RENAISSANCE	74 - 79
TA.ta wood	80 - 83
ICS	84 - 85
TUB	86 - 87

88 - 113 TAVOLINI LOW TABLES

TEA	90 - 95
JEAN	96 - 101
NAZCA	102 - 105
KURTZ	106 - 107
MARLOW	108 - 109
TOC	110 - 111
InsTABLE	112 - 113

114 - 145 SEDUTE SEATINGS

MILLEMIGLIA SUPER	116 - 121
MILLEMIGLIA	122 - 125
CROSS CHAIR	126 - 129
CROSS ARMCHAIR	130 - 133
EXPERIMENTA	134 - 137
GRAFT	138 - 141
SEMUC	142 - 145

146 - 155 COMPLEMENTI COMPLEMENTS

b2b	148 - 149
SEED	150 - 151
EDES	152 - 153
ETNA	154 - 155

156 - 179 ACCESSORI ACCESSORIES

AMO	158 - 159
JOINT	160 - 161
QUATTROQUARTI	162 - 163
NORMANN	164 - 165
QUBO	166 - 167
SUSHI	168 - 169
STELO	170 - 171
MELA/PERA	172 - 173
LUME	174 - 175
ASÈT	176 - 177
BOCCIA	178 - 179

180 - 203 DATI TECNICI TECHNICAL DATA

Durame si riserva il diritto di apportare in qualsiasi momento e senza alcun preavviso, modifiche tecniche, dimensionali ed estetiche che ritenga necessarie per un miglioramento funzionale e qualitativo dei propri prodotti.

Testi e disegni presenti in questo stampato hanno scopo divulgativo: per ogni aspetto tecnico e dimensionale fare riferimento ai listini aziendali e relativi aggiornamenti.

Le possibili differenze di tonalità o sfumature di colore sono da considerarsi caratteristiche naturali dei materiali a dimostrazione dell'artigianalità della lavorazione.

I campioni di colori e materiali hanno valore indicativo.

Durame reserves the rights to apply technical/dimensional/aesthetic amendments for a functional and qualitative improvements of its products, at any time and without any notice obligation.

Texts and drawings present in this catalogue have a divulgative purpose: for every technical and dimensional aspect please refer to the company's price lists and their relative updates.

Differences in color tonality or shades are to be considered natural characteristic of the materials and a demonstration of the crafted processing.

Color and material samples have an indicative value.

GRAPHIC:
studio grafico
ruggero marelli | cantù

PHOTOGRAPHY:
studio eleven | mariano c.se

PRINT:
editoria grafica colombo srl | valmadrera

A.D.:
crs DURAME | cantù

07.2018 - #3

DURAME[®]

Via dell' Artigianato 20
22063 Cantù (CO) Italy
Telefono/Fax 031 734910
www.durame.it
info@durame.it

