

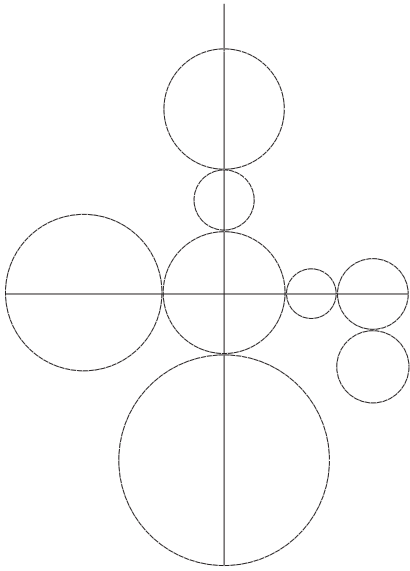

Catalogue  
2019



## Products



**Orbit Collection**  
Studio Bohinc

**Echo Collection**  
Uffie

**Luminarie Collection**  
Sabina Belfiore

**Clean Sweep & Spun Halo**  
Umut Yamac

**The Veiled Collection**  
Olga Bielawska

**Contrasti Collection**  
Moreno Ratti

**Svelata Vases**  
Moreno Ratti

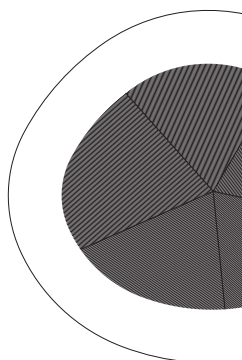
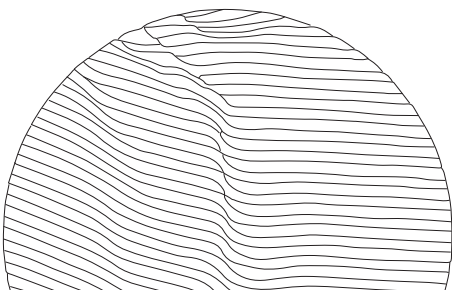
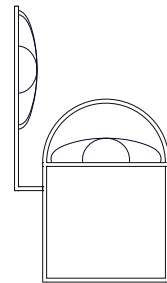
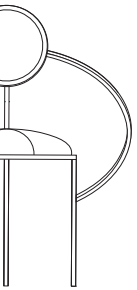
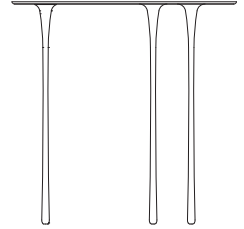



**Orbit**  
by Studio Bohinc

# Orbit collection

design Studio Bohinc

2018

Finding inspiration in planetary orbits, whose gravitationally curved trajectories drive the lines and shapes of the designs. Constructed from thin square metal rods, the designs play with circles and straight lines to create pieces that are delicate, light but complex. The pieces are manufactured from 12 mm square steel rods, which are laser-cut and welded to form combinations of semi circles and straight lines. Fabricated in either dark chocolate bronze or a brass coated steel.

## Materials

Galvanized steel and wool fabric

## Sizes

**Lunar Chair**  
63 × 66 × 84h cm

**Solar Chair**  
45 × 55 × 98h cm

**Orbit Chair**  
80 × 55 × 88h cm

**Orbit Dining Chair**  
45 × 55 × 89h cm

## Finishes





Lunar Chair



Solar Chair



Orbit Chair



Orbit Dining Chair



# Colour Examples

\*More combinations are possible and can be requested

## Lunar Chair



Pink+Black frame



Petrol Blue+Brass frame

## Solar Chair



Pink+Black frame



Red+Brass frame



Black+Black frame

## Orbit Chair



Pink+Black frame



Petrol Blue+Brass frame



Black+Black frame

## Orbit Dining Chair



Dark Blue+Brass frame

## Dimensions

### Lunar Chair

63 × 66 × 84h cm

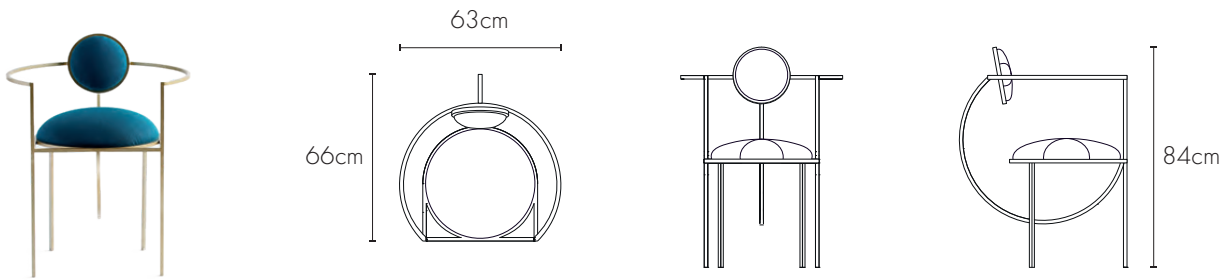

### Solar Chair

45 × 55 × 98h cm

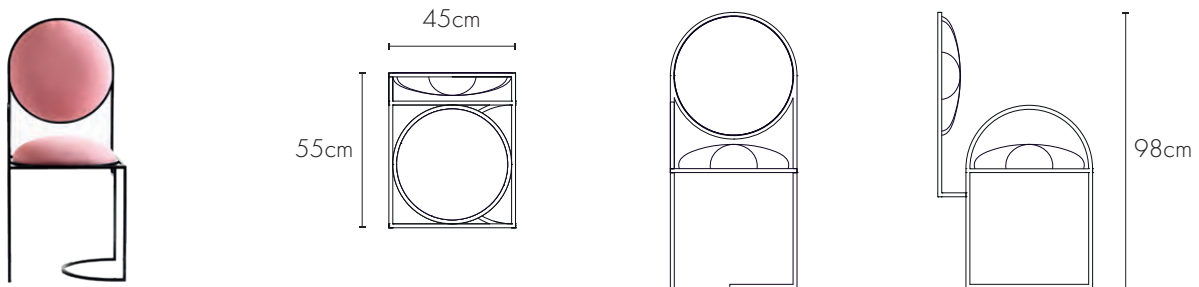

### Orbit Chair

80 × 55 × 88h cm

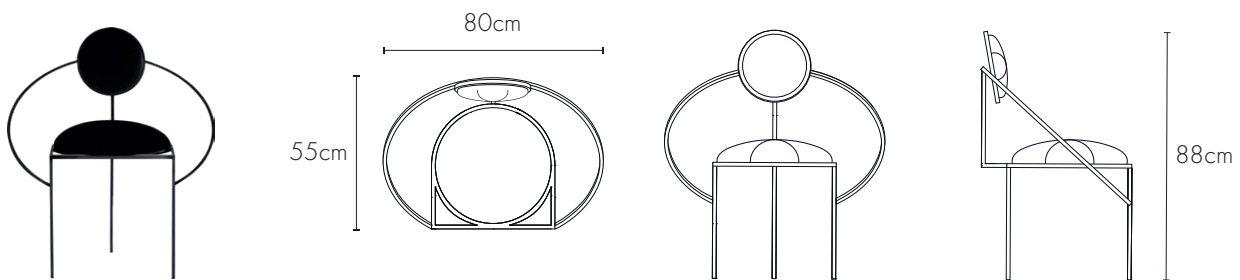

### Orbit Dining Chair

45 × 55 × 89h cm

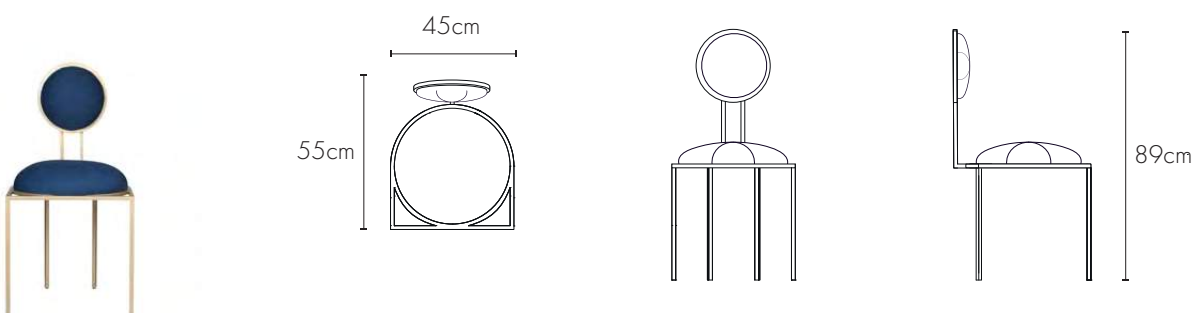

**Pesi in Pasta**

BRUNETTONI (5)	COLOMB
0.250 - 0.250	0.250
0.750 - 0.850	0.750
1.000 - 1.120	0.500
1.500 - 1.650	1.500
2.000 - 2.200	COLOMB
1.000 - 1.100	0.500
BRUNETTONI (3.000)	0.500
COLOMB	0.500
BRUNETTONI	0.750
BRUNETTONI	COLOMB
BRUNETTONI 0.530 - 0.630	0.570
BRUNETTONI (5)	COLOMB
500	0.500
2000	0.500
3000	0.500

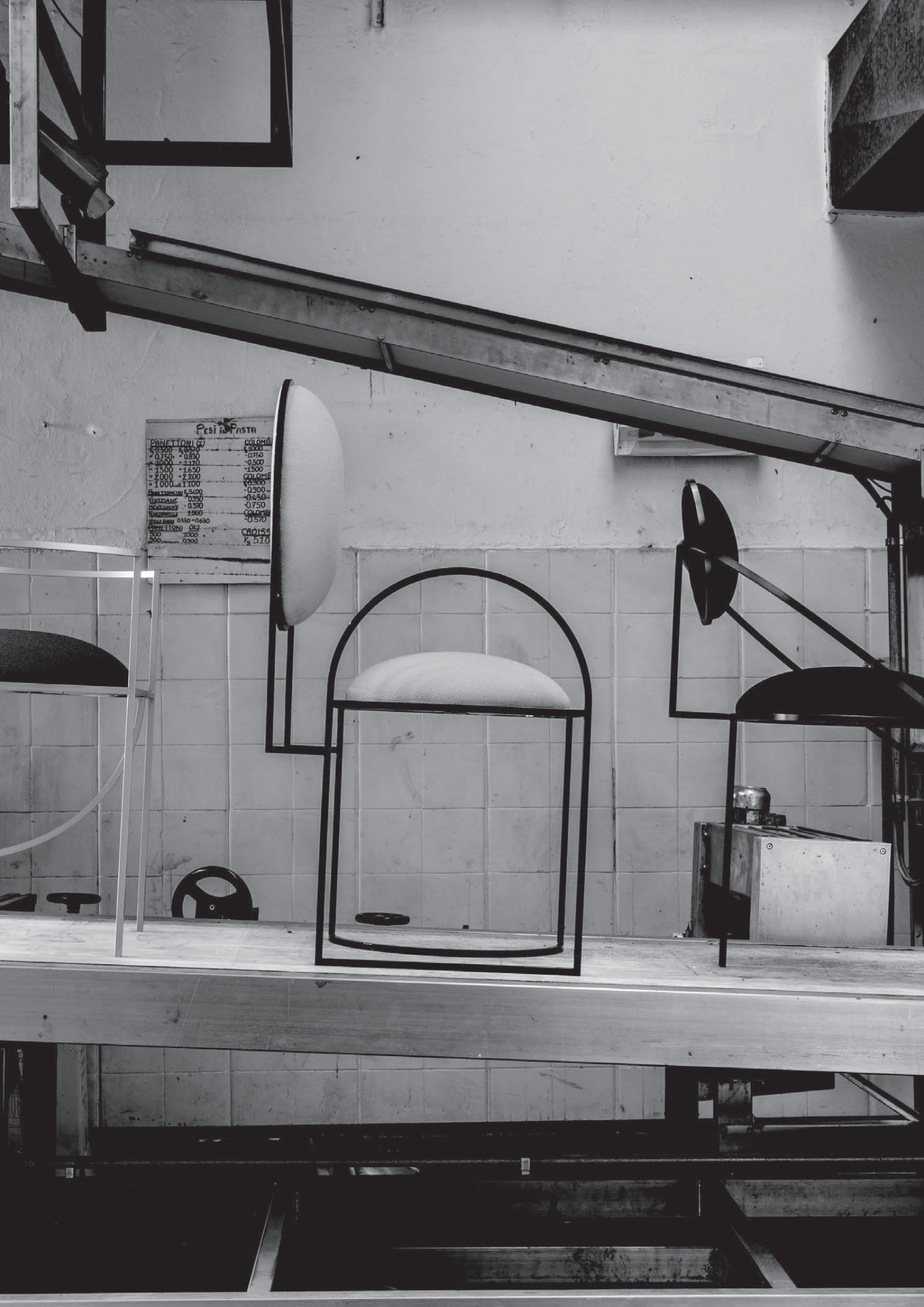



**Echo Tables**  
by Uuufie

## Echo Table collection

design Uffie

2016

The "echo" table pushes the material limits of metal and wood to imagine an intangible reality. The grain of wood tells its history, and by using a technique of exposing the hardwood (season of winter) and embedded metal into the lines of the softwood (season of summer), each growth creates an elusive boundary between the two materials. The colours allude to the subtle shades of a sunrise, created in three metal: aluminium, copper, and brass.

### Customisable

Sizes and finishes can be customised to client specification

### Sizes

**Large Dining table**  
250 × 115 × h72 cm

**Dining table**  
140 × 160 × h70 cm

**Coffee table**  
120 × 70 × h30 cm

**Side table**  
50 × 49 × h50 cm

### Materials

Wood, Aluminium, Copper and Brass







Side Table | Copper







Coffee Table | Brass



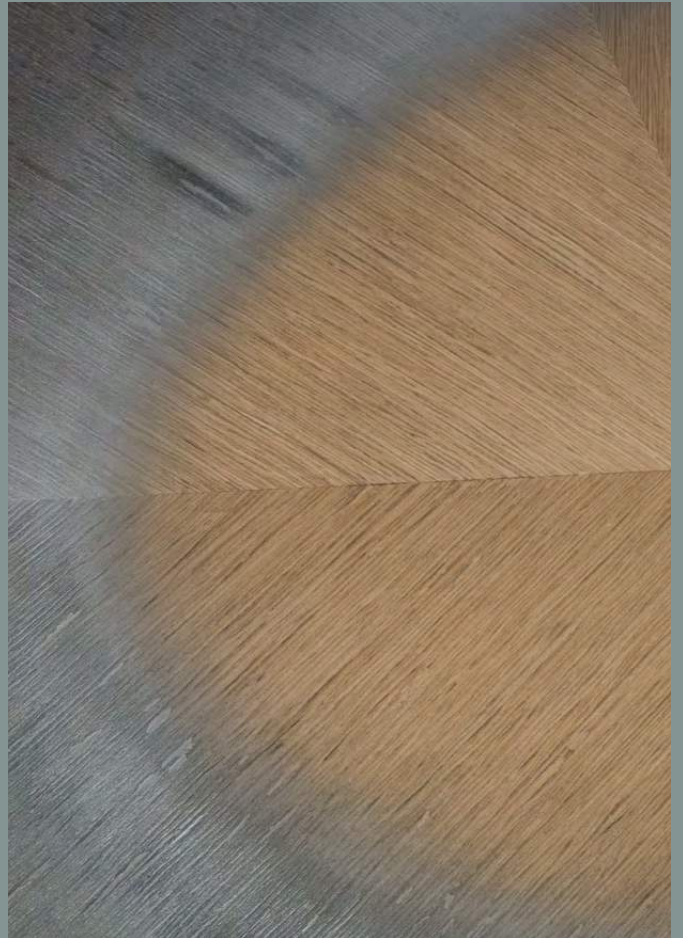

Dining Table | Aluminium

## Dimensions

### Echo Side table

50 × 49 × h50cm

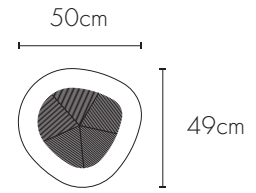
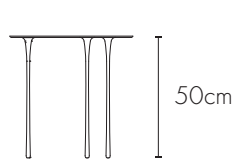

### Echo Coffee table

120 × 70 × h30cm

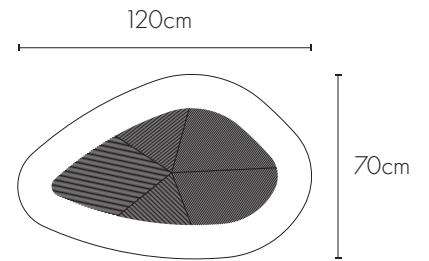
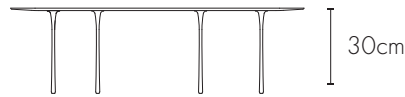

### Echo Dining table

140 × 160 × h70cm

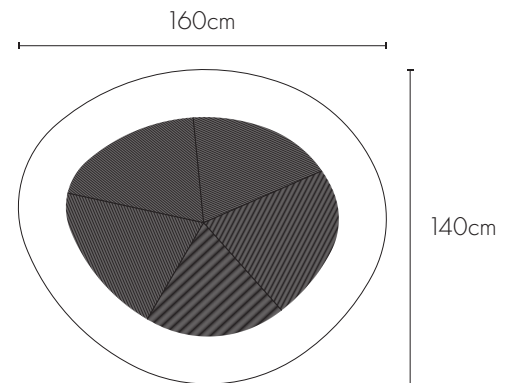
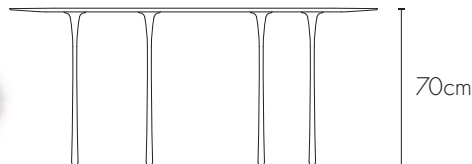

### Large Dining table

250 × 115 × h72 cm

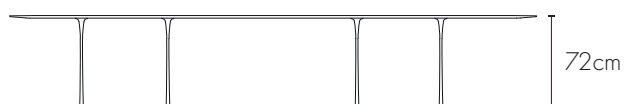
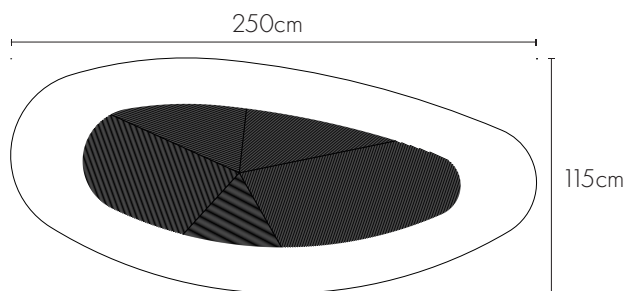



[www.matterofstuff.com](http://www.matterofstuff.com)

Luminarie  
by Sabina Belfiore

# Luminarie

design Sabina Belfiore

2018

Luminarie is an expressive study of lighting as a poetic object, inspired by the designer's memories of lights at religious festivals in southern Italy. The Luminarie lighting mobile uses LED technology applied not to a functional lamp but to a sentimental, ethereal and poetic work of art. Tactile, playful, illusory and mobile, Luminarie are very light-weight, ethereal structures; handcrafted in Italy from copper and with micro LEDs.

## Models

**Belladonna**  
102 × 104h cm

**Novina**  
75 × 102h cm

**Candelora**  
80 × 145h cm

**Santamaria 1**  
161 × 174h cm

**Santamaria 2**  
135 × 172h cm

**Flora Medium**  
23.6 × 183h cm

**Flora Large**  
23.6 × 230h cm

**Angelo**  
23.6 × 220h cm

## Materials

Steel, Copper finish and Micro LEDs



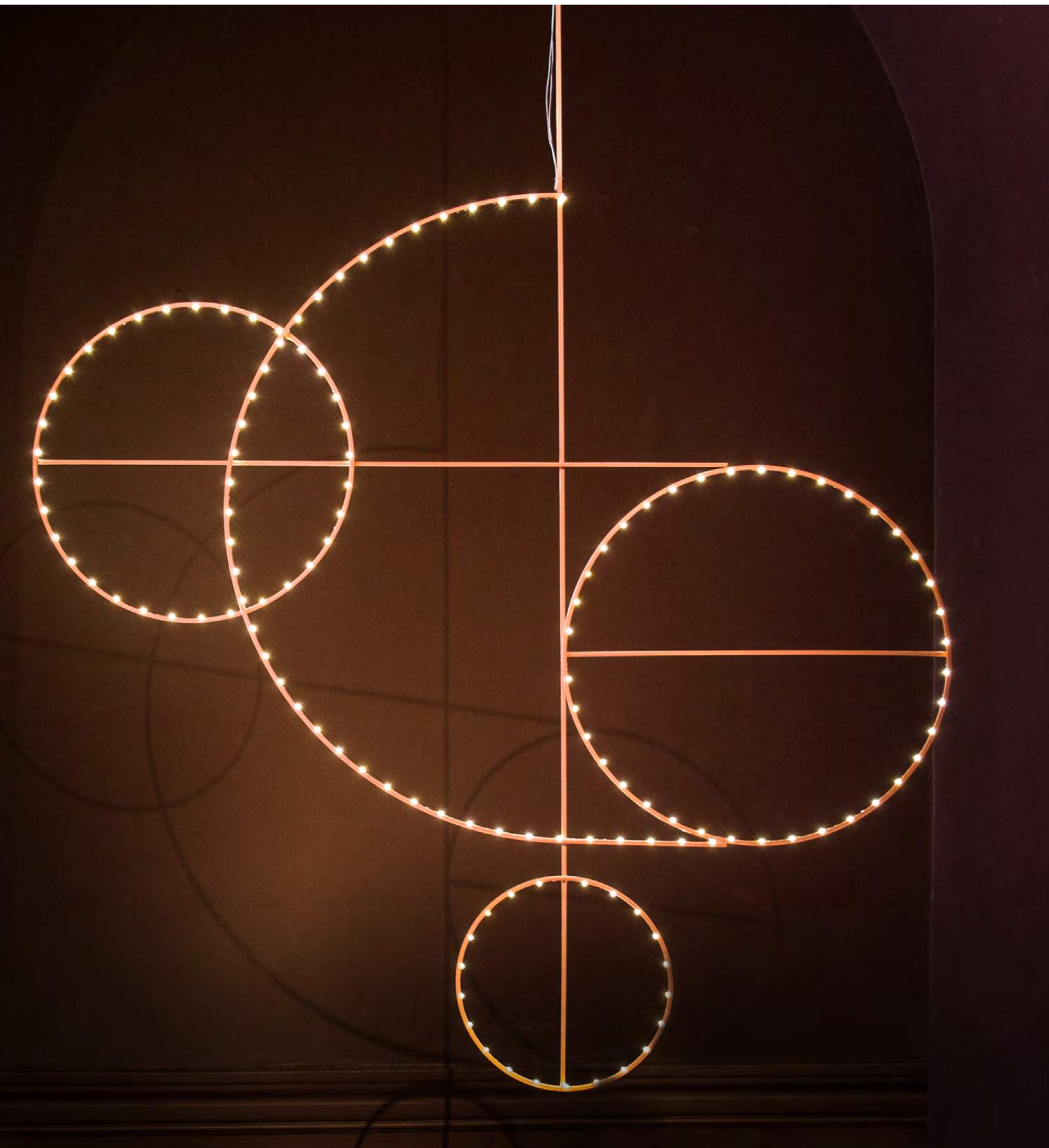

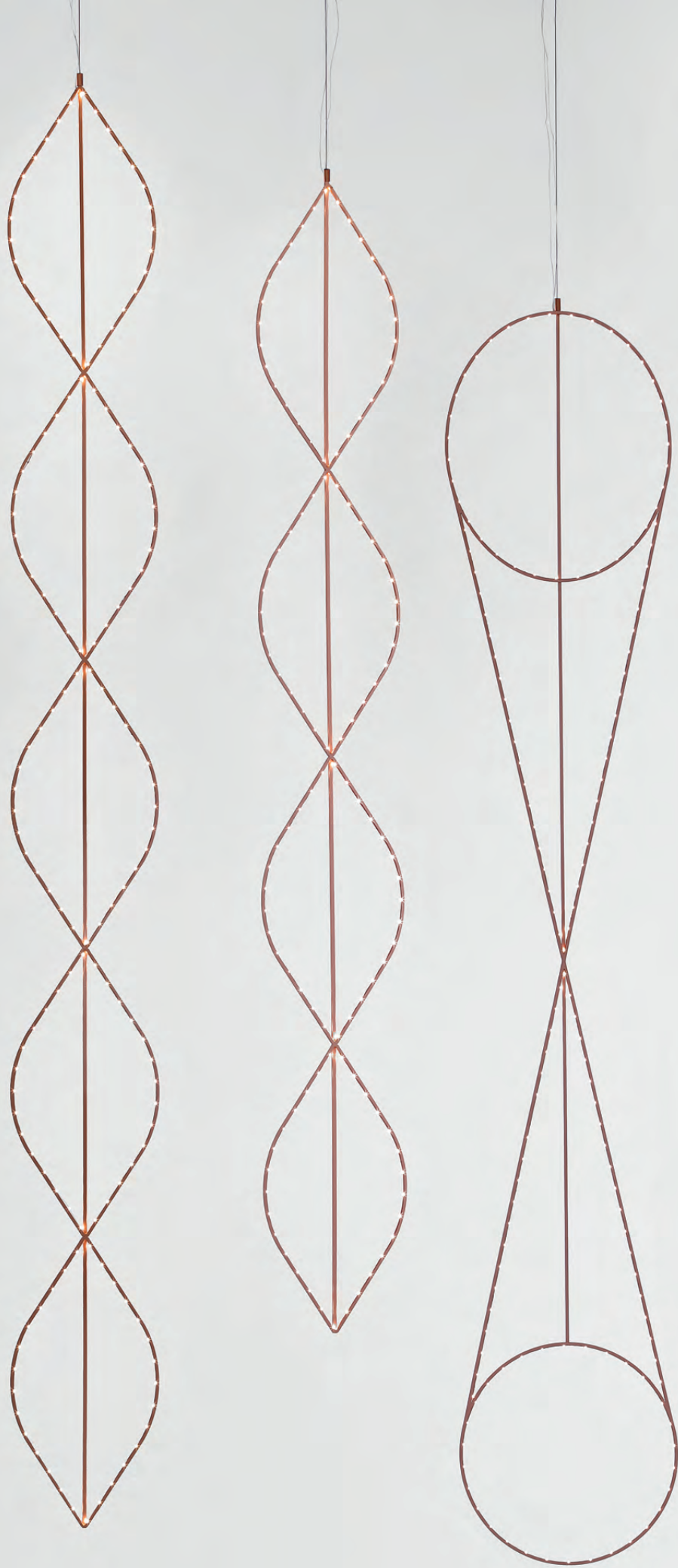

Luminarie | Flora Large & Medium | Angelo



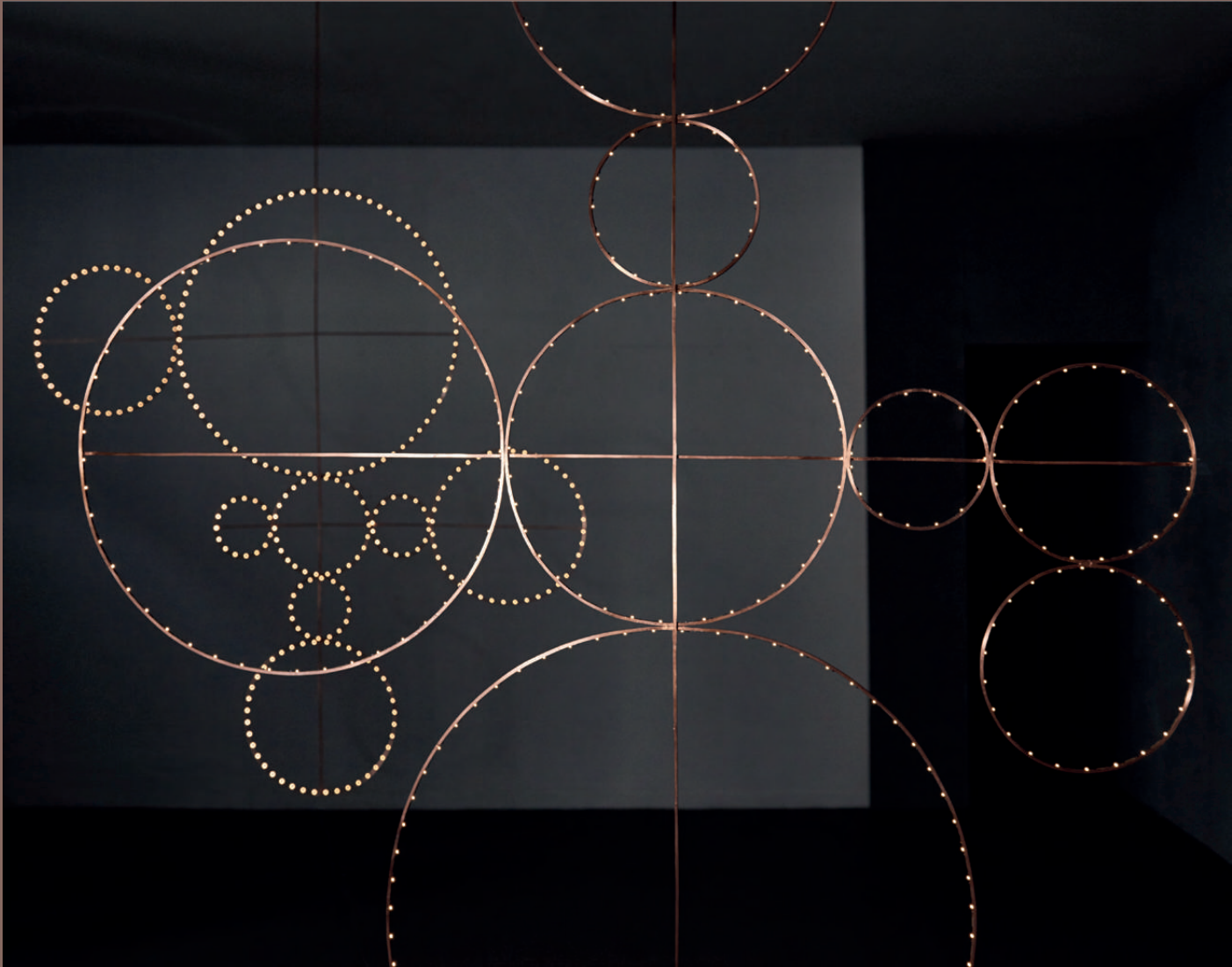

Luminarie | Santa Maria 1 & 2

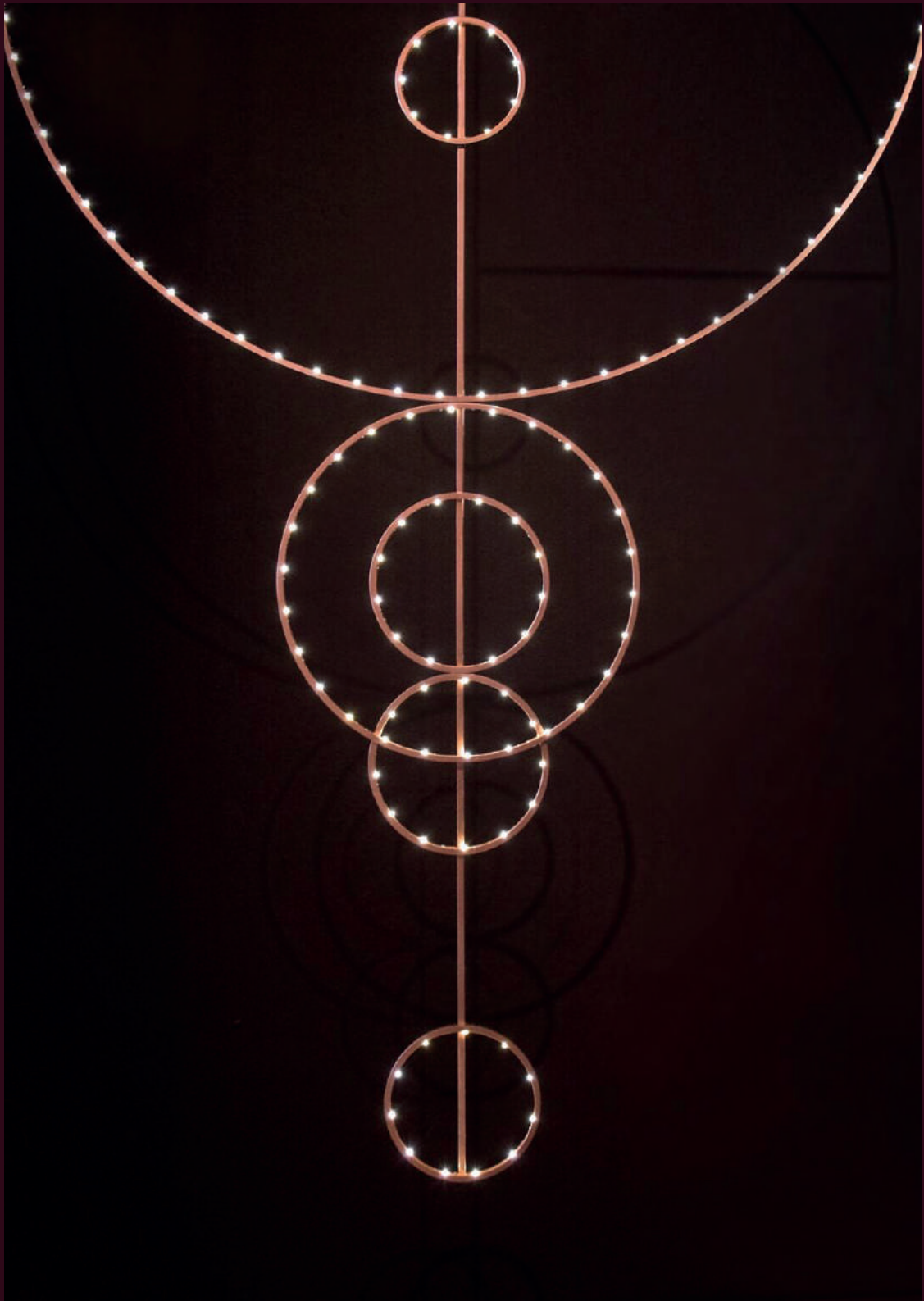

Luminarie | Candelora

# Dimensions

**Belladonna**

102 × 104h cm

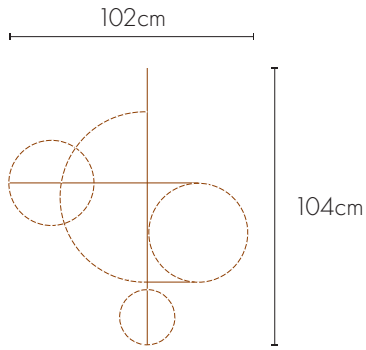

**Novina**

75 × 102h cm

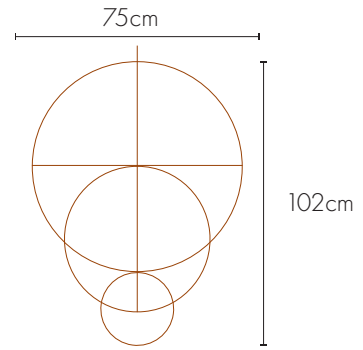

**Candelora**

80 × 145h cm

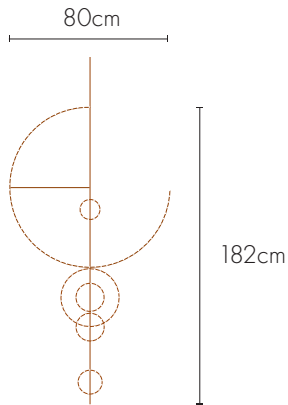

**Santamaria 1**

161 × 174h cm

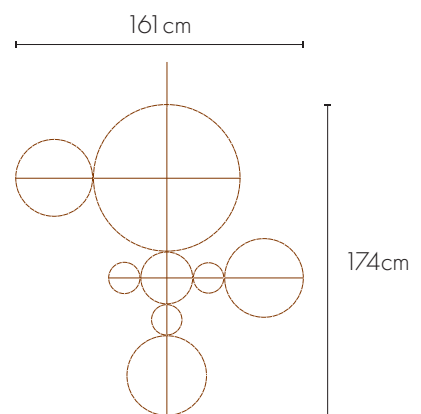

**Santamaria 2**

135 × 172h cm

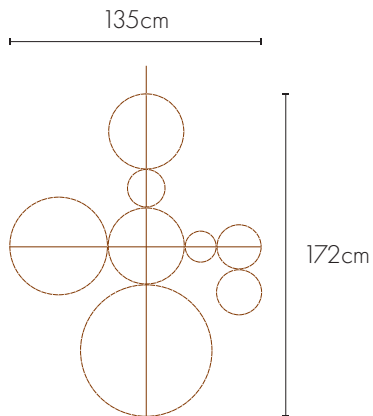

**Flora Medium**

23.6 × 183h cm

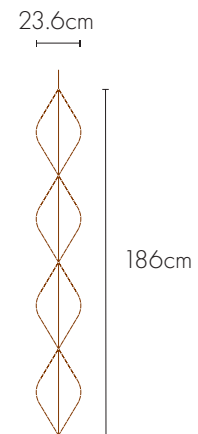

**Flora Large**

23.6 × 230h cm

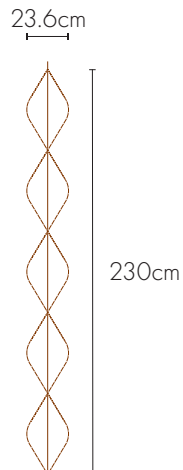

**Angelo**

23.6 × 220h cm

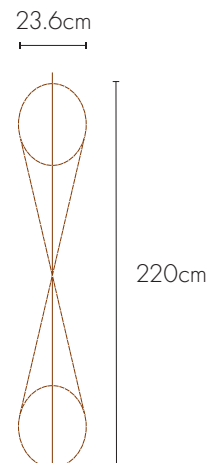



Clean Sweep  
by Umut Yamac

# Clean Sweep

design Umut Yamac

2018

Clean Sweep is a sculptural time piece composed of a large brass disc which rotates very slowly down a vertical stem, making one revolution over a period of approximately 12 hours. The brass disc is oxidised with a rich, coloured patina that is gradually cleaned away by brushes within the armature as the disc rotates on its journey downwards. Concentric rings of cleaned brass contrast with the patinated surface, offering a continually changing canvas and a different way to think about the passage of time.

## Dimensions

70 × 30 × 210h cm

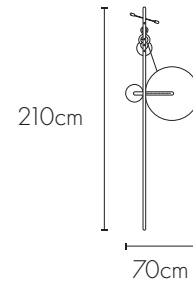

## Materials

Timber, Brass, Steel and Rope

## Customisable

Sizes and finishes can be customised to client specification

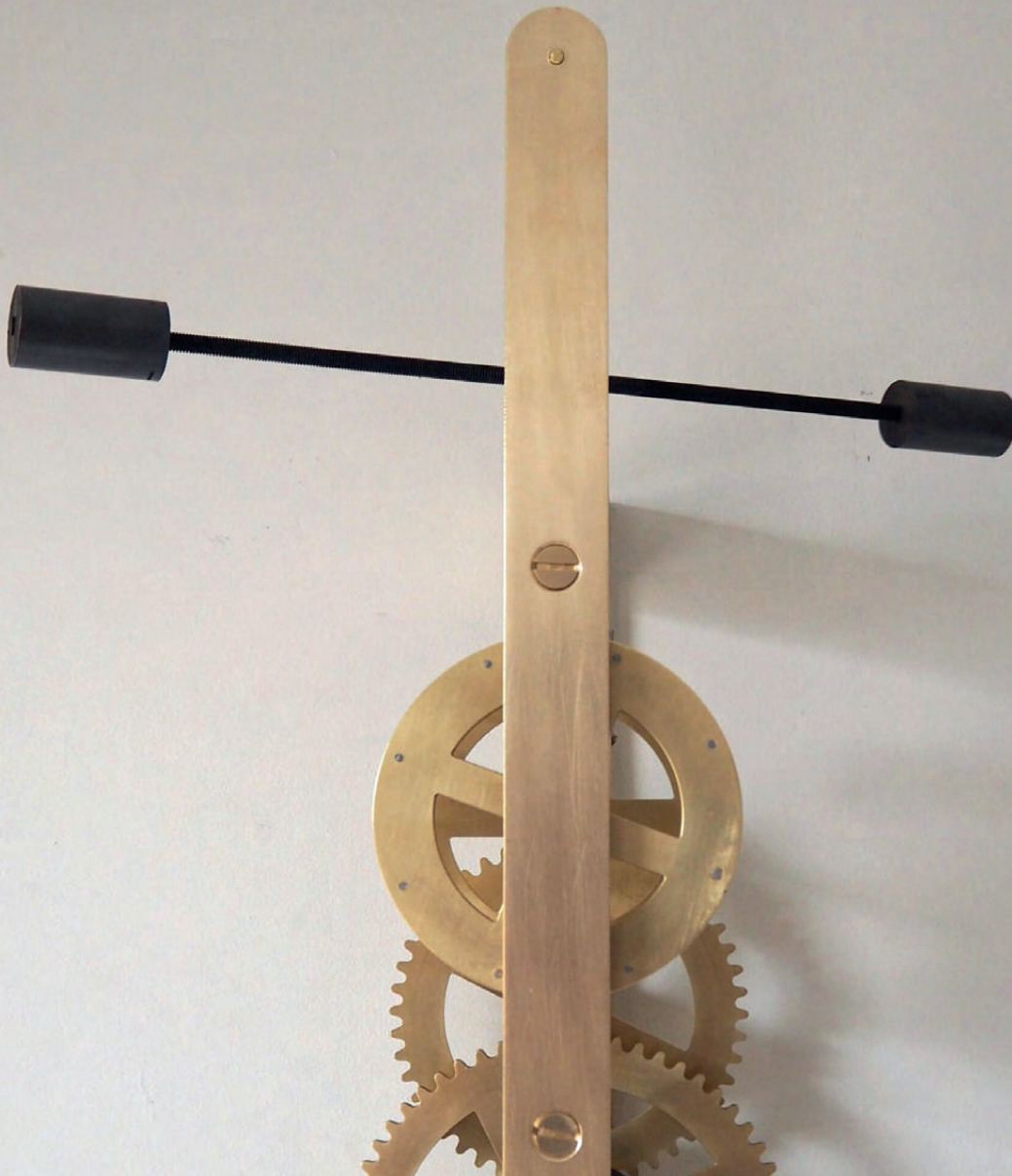

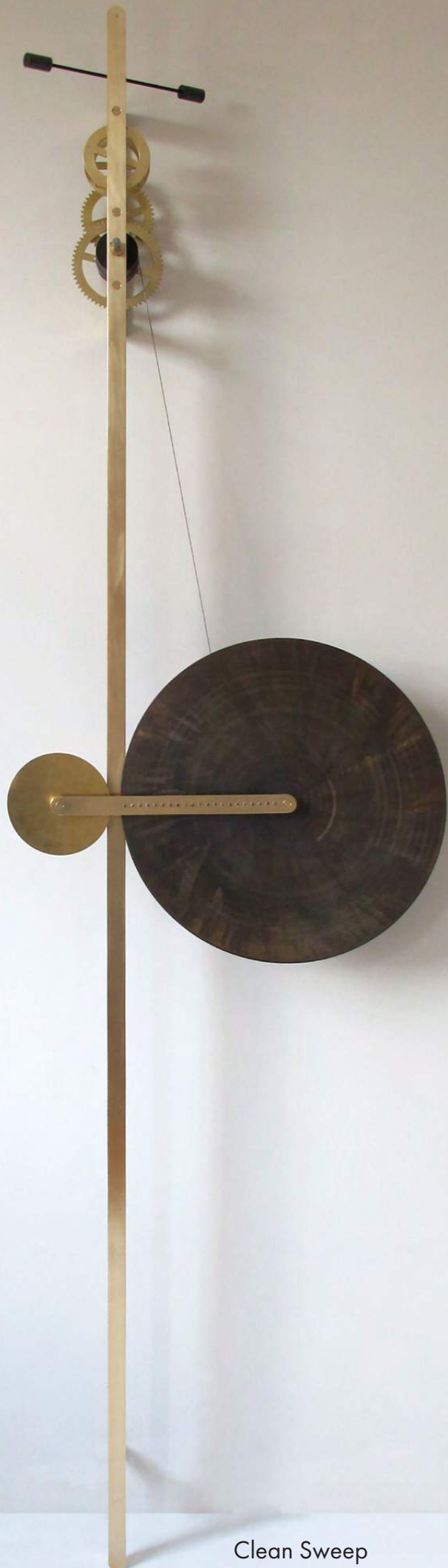

Clean Sweep

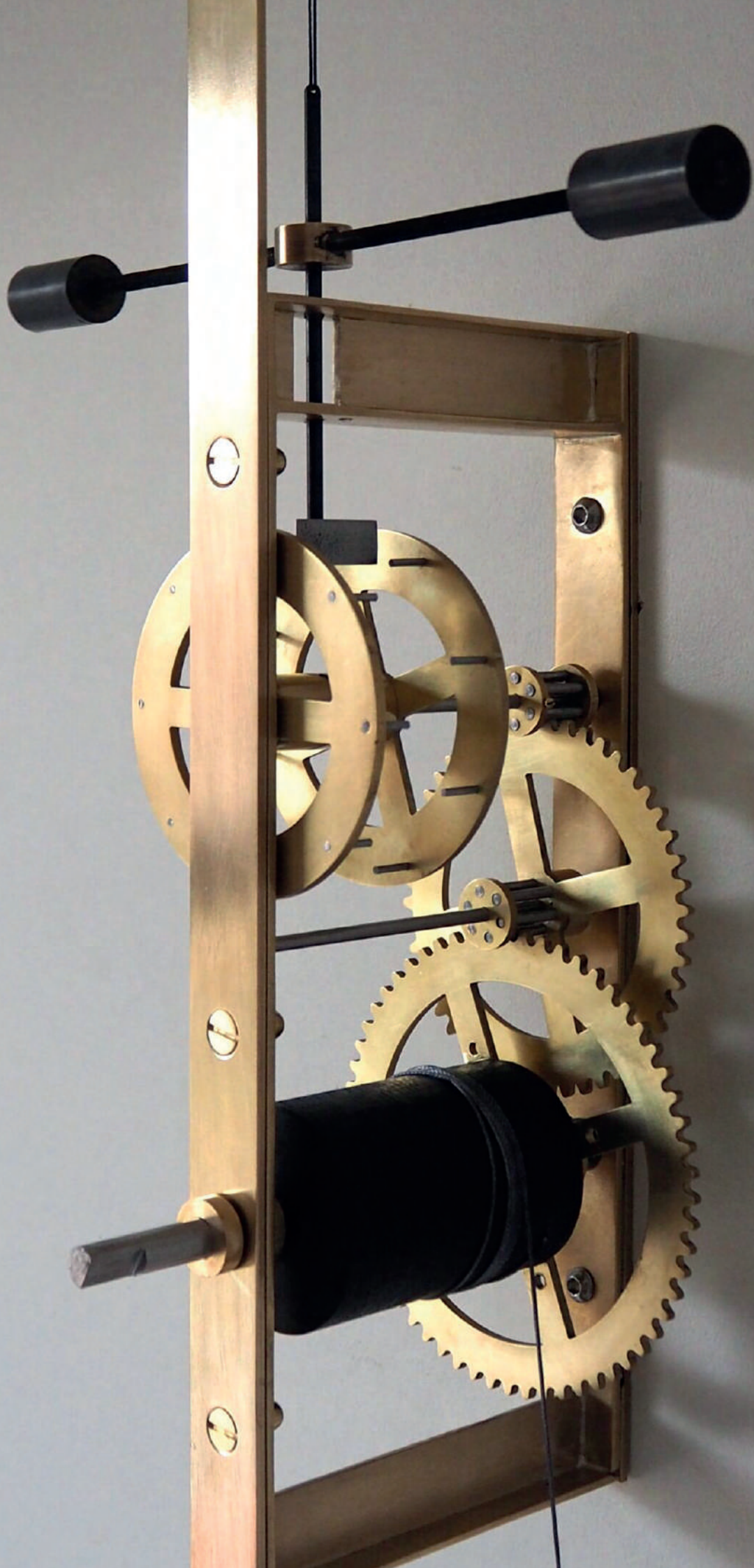



**Spun Halo**  
by Umut Yamac



# Spun Halo pendant

design Umut Yamac

Spun Halo is a new light sculpture which explores the potential of thread, a normally invisible material, to create and define volumes of light. Consisting of over 600 meters of thread, Spun Halo has been hand woven to create two intersecting volumes, each suspending a ring of light in mid-air. The criss-crossing threads create what appears to be a new volume within the light, and the effect of their layering is a large-scale interference pattern, or moire, which creates the illusion of movement as you move around the light.

2018

## Dimensions

Ø60.5 × 160h cm

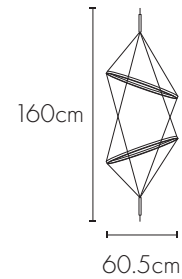

## Materials

Brass and thread

## Customisable

Sizes and finishes can be customised to client specification

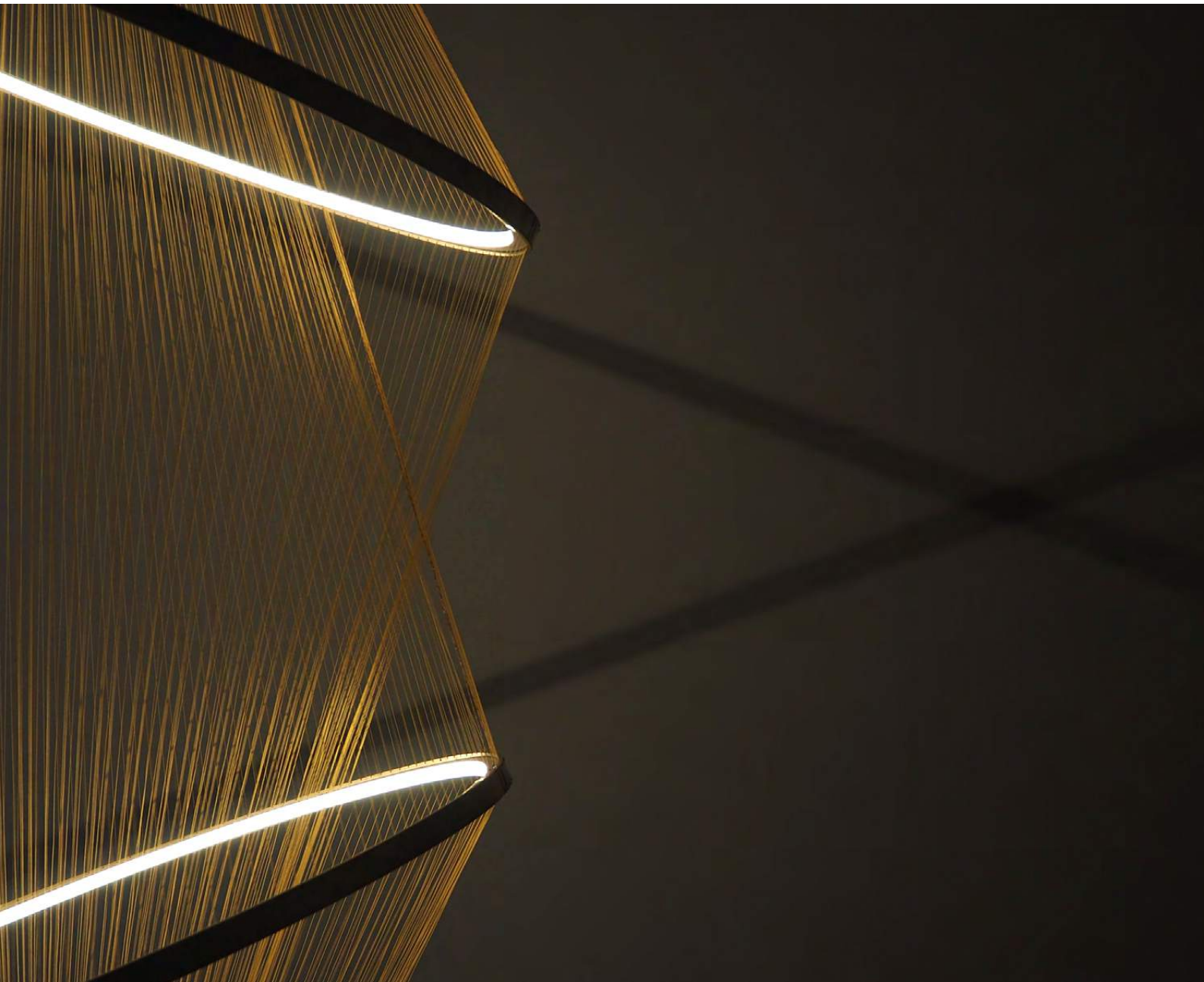



Spun Halo pendant





**The Veiled**  
by Olga Bielawska

# The Veiled

design Olga Bielawska

2016

The Veiled is a collection of tables made of marble with a graphical pattern inspired by an ancient statue. It experiments with the dichotomy between a silk and soft looking surface for a hard material like marble. The effect of light and dark-coloured marble in stripes is both graphic and illusional. The pattern catches your eye and invites you to touch. It combines a modern technique and aesthetic with the traditional way of making inlays.

## Customisable

Sizes and finishes can be customised to client specification

## Sizes

Oval 2 marble legs  
120 × 47 × 40h cm

Round Small Ø70

1. 40h in metal
2. 40h in marble

Round Large Ø160

1. 40h in metal
2. 75h in 3 marble legs
3. 75h in single metal leg

## Materials



White  
Carrara

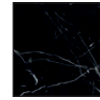

Nero  
Marquina

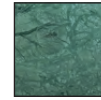

Guatemala  
Verde



Blue  
Macauba



Bardiglio  
Nuvolato



Rosa  
Portogallo

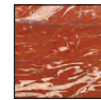

Red  
Francia

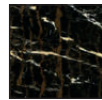

Black  
Gold





Round Large | Metal



Round Small | Round Large

## Dimensions

### Oval Coffee Table - 2 Marble Legs

120 × 47 × h40 cm

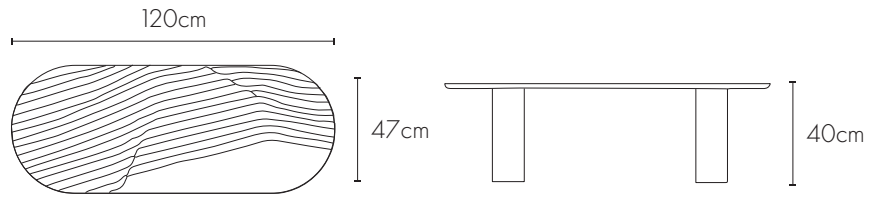

### Round Large Coffee Table - Metal

Ø160 × h40 cm

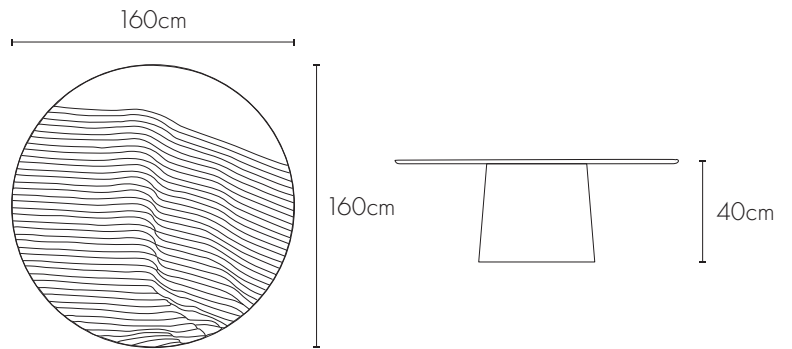

### Round Large Dinner Table - 3 Legs Marble

Ø160 × h75 cm

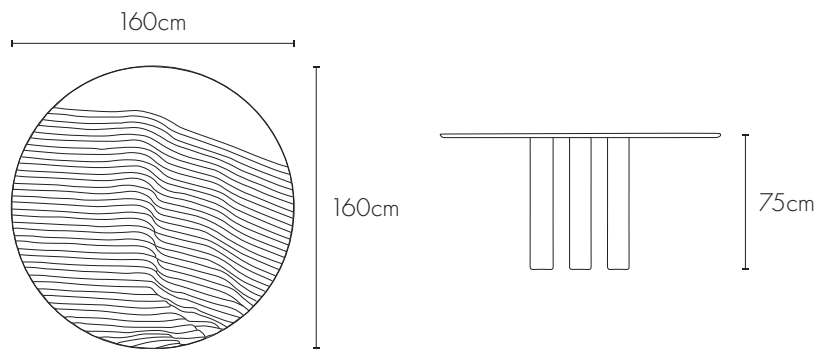

### Round Large Dinner Table - Metal

Ø160 × h75 cm

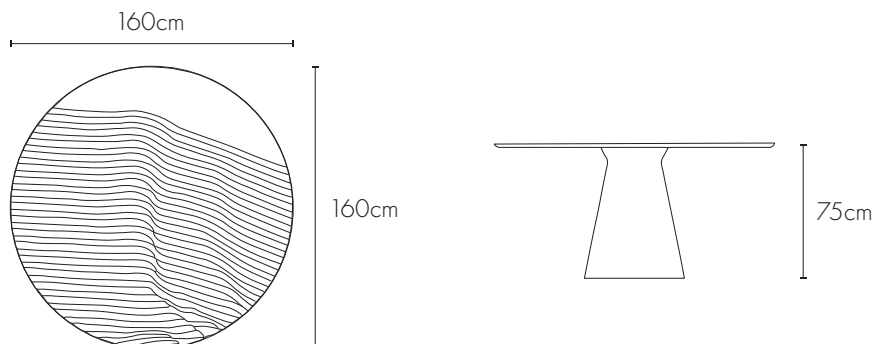



## Dimensions

---

Round Small Side Table - Metal

Ø70 × h40 cm

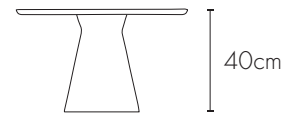
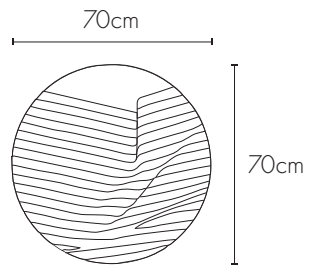

---

Round Small Side Table - Marble

Ø70 × h40 cm

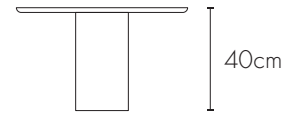
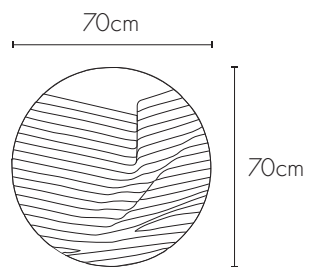





Contrasti  
by Moreno Ratti

# Contrasti

design Moreno Ratti

2016

The idea comes up from the will to emphasize the contradictions of natural resource waste. The marble is recovered and assembled to make a 3D module. This module has been finished to highlight the contrast of the linear and geometric side with the random texture that emerge with the cnc machine.

## Sizes

### Small

15 × 15 × 15h cm

### Medium

15 × 15 × 20h cm

### Large

15 × 15 × 34h cm

## Materials

Carrara Marble





Contrasti Set





**Svelata**  
by Moreno Ratti

# Svelata

design Moreno Ratti

2016

Series of handmade vases made from a single piece of Carrara Marble. The idea is born from the desire to create a timeless flower pot, which is classic and modern at the same time, just as the material it is made of. The vessels in Collezione Svelata are unique pieces, handcrafted out of white Carrara marble exclusively for Matter of Stuff. The relationship between the modern and classical forms is revealed thanks to the Artisan who carves the piece. Developed and Produced during the Matter of Stuff Designer Residency program in Montalcino

## Sizes

### Tall

12 × 12 × 34h cm

### Short

15 × 15 × 15h cm

## Materials

White Carrara Marble







